



SERIES 70 10K PSI / 700 BAR / 7000 M SeaKing™ High-Pressure Subsea Connectors, Cables, and PBOF Assemblies

700-006 flange connector receptacle (FCR)



SeaKing FCR - How To Order						
Sample Part Number	700	-006-	O19	-Z1	P	N
Product Series	700 = SeaKing™					
Connector Style	006 = Flange connector receptacle					
Shell Size-Contact Arrangement	See SeaKing contact arrangements table (pgs. 4-5)					
Shell Material	Z1 = 316 Stainless steel TC = Titanium					
Contact Style	P = Pin					
Alternate Key Position	A, B, C, N = Normal (see alternate key positions table)					

NOTES

- Double O-ring sealing:
 - Flange and piston O-rings to bulkhead
 - Dual piston O-rings at insert
 - Flange and piston O-rings in mated condition
- Mates with 700-001 series SeaKing
- Material/Finish
 - Shell: 316 stainless steel or titanium
 - Contacts: Inconel X750, gold plated
 - Insert: Inconel X750
 - Insulator: Fused vitreous glass
 - O-ring: Nitrile (NBR)

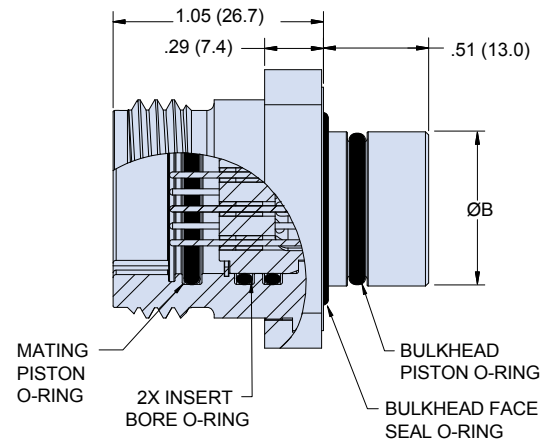
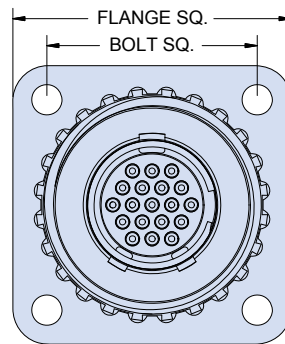

Alternate Key Positions		
	A°	B°
Position	A°	B°
N	150°	210°
A	75°	210°
B	95°	230°
C	140°	275°

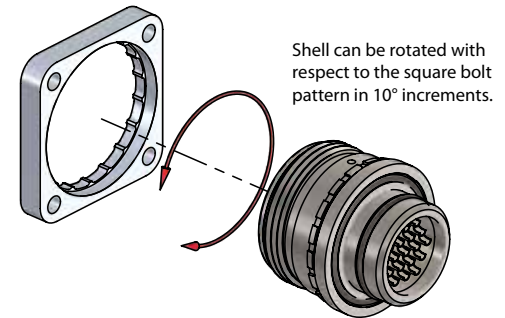
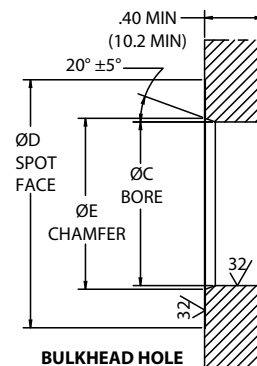

Dimensions												
Shell Size	Flange Sq.	Bolt Sq.	Bulkhead face seal O-ring	Bulkhead piston O-ring	Mating Piston & Insert O-ring	Retaining Ring	Ø B	Ø C +.002(+.05) -.000(-.00)	Ø D Min. Spotface ≤.005 ▽	Ø D Min Spotface > .005 ▽	Ø E	Flange Screws
G	1.20 (30.48)	.906 (23.01)	2-018	2-015	2-014	VH-50-S02	.685 (17.40)	.687 (17.45)	1.080 (27.43)	1.600 (40.64)	.737 (18.72)	#4-40
K	1.35 (34.29)	1.020 (25.91)	2-019	2-016	2-016	VH-62-S02	.748 (19.00)	.750 (19.05)	1.205 (30.61)	1.795 (45.59)	.800 (20.3)	#6-32
L	1.47 (37.34)	1.124 (28.55)	2-021	2-018	2-018	VH-75-S02	.873 (22.17)	.875 (22.23)	1.330 (33.78)	1.960 (49.78)	.925 (23.50)	#6-32
M	1.60 (40.64)	1.186 (30.12)	2-022	2-020	2-019	VH-81-S02	.998 (25.35)	1.000 (25.40)	1.465 (37.21)	2.115 (53.72)	1.050 (26.67)	#8-32
O	1.87 (47.50)	1.446 (36.73)	2-026	2-022	2-023	VH-106-S02	1.123 (28.52)	1.125 (28.58)	1.705 (43.31)	2.660 (67.56)	1.175 (29.85)	#8-32
Q	2.18 (55.37)	1.662 (42.21)	2-029	2-026	2-028	VH-137-S02	1.373 (34.87)	1.375 (34.92)	1.955 (49.66)	2.890 (73.41)	1.425 (36.20)	#10-24
R	2.30 (58.42)	1.768 (44.91)	2-030	2-028	2-029	VH-150-S02	1.498 (38.05)	1.500 (38.10)	2.080 (52.83)	3.050 (77.47)	1.550 (39.37)	#10-24

SUBSEA/DEEPWATER: SEAKING™

