

Datasheet

Syrinx – Doppler Velocity Log



Description

The Syrinx DVL is a class leading Doppler Velocity Log that builds on Sonardyne's existing product range of acoustic instrumentation by bringing to market a high integrity, high performance instrument.

Syrinx can be used as a standalone navigation instrument or can be integrated into Sonardyne's SPRINT system or other 3rd party navigation systems.

This new DVL provides the best of both worlds in a single unit available in depth options of 4000 & 6000 metres. With a large altitude range and high precision at all altitudes, this combines the best of 300 and 1200 kHz DVLs.

Syrinx utilises both Doppler and Correlation technology to gain performance advantages in environments where each technology is best suited.

Processing techniques have been refined to avoid any loss in output measurements including undulating and sharp roll off terrain of any type. The instrument has been tested over

terrains with near vertical gradients to ensure velocity estimates are always provided, even when individual beam data can show vast differences in altitude.

Adaptive signalling techniques utilise the best signal type for the environment and terrain, this allows both low and high altitude class leading performance.

Syrinx allows users to simultaneously output data of different formats, so you can provide the ROV crew with one data format and your survey crew another. This reduces the requirement of more than one DVL on board the ROV, saving on weight and costs.

Sonardyne have developed the transducers to be singularly interchangeable, dramatically reducing maintenance costs and times.

From April 2017 an internal bulkhead is fitted to protect the main chamber (containing the internal electronics) from water ingress should a transducer become badly damaged.

Key Features

- Class leading 600 kHz DVL combining the benefits of 300 and 1200 kHz instruments in one
- Reliable adaptive bottom lock
- Capsule case design built around field proven USBL array capsules developed over last 30 years
- Concurrent Ethernet and serial connectivity
- Individually replaceable transducers
- On-board DVL Manager web interface for configuration and diagnostics
- Standard 4000 m titanium housing for Work Class ROVs
- Full linear signal processing
- Up to 25 Hz ping rate
- 0.4 to 175 m operation range
- Tight integration to Sonardyne SPRINT INS, providing unmatched DVL aided navigation even in challenging bottom lock conditions
- Internal bulkhead prevents water ingress if a transducer is damaged

Specifications

Syrinx – Doppler Velocity Log

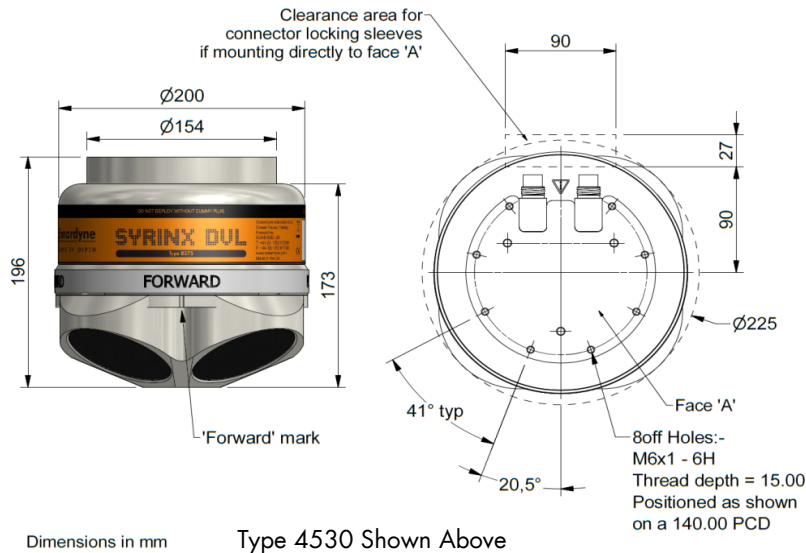

Features

		Type 8275-4530/6530
Operating Frequency		600 kHz
Bottom Velocity – Single Ping Precision	Standard Deviation @ 1 m/s*	±0.22 cm/s
Long Term Accuracy		±0.12% ±0.1 cm/s
Minimum/Maximum Altitude		0.4/175 m
Velocity Range		>10 m/s
Velocity Resolution		0.01 cm/s
Data Output Rate		25 Hz max
Maximum Transmit Source Level (dB re 1 uPa @ 1 m)		217 dB
Water Reference Velocity	Accuracy	±0.2% ±0.1 cm/s
	Layer Size	Selectable
	Minimum/Maximum Range	0.5 m/70 m
Sensors	Temperature	-5° to 40°C
	Pitch/Roll (Optional)	±0.5°
	Pressure (Optional)	±0.1% full scale
Configuration	Array	4-beam array @ 30° beam angles
Communication and Logging	Communications	Dual RS232, multi-port Ethernet (TCP & UDP)
	Trigger Inputs	3 V-12 V rising or falling edge configurable
	Internal Logging	32 GB internal memory
Output	Output Telegrams	Sonardyne proprietary, PDO, PD3, PD4, PD6, PD13, SDDBT
		Simultaneous telegram output
Power	Voltage Range (DC Input)	24 V (±10%)
	Average Power (Typical)	10 W
Environmental	Depth Rating	4000 m/6000 m
	Operating Temperature	-5 to 55°C
	Storage Temperature	-20 to 55°C
Mechanical Construction	Titanium	
Dimensions (Height x Max Diameter)		196 x 225 mm (4,000 m)/ 208 x 225 mm (6,000 m)
Weight in Air/Water**		12/7 kg (4000 m) - 15/9 kg (6,000 m)

*Standard deviation refers to proven single-ping true horizontal velocity precision, specified at 20-30 m altitude.

**Estimated weights