

6205S BATHYMETRY & SIDE SCAN SYSTEM

USER HARDWARE MANUAL

0020300_REV_B

1/4/2019



EdgeTech
4 Little Brook Road
West Wareham, MA 02576

Tel: (508) 291-0057
Fax: (508) 291-2491
www.EdgeTech.com

The information, figures, and specifications in this manual are proprietary and are issued in strict confidence on condition that they not be copied, reprinted, or disclosed to a third party, either wholly or in part, without the prior, written consent of EdgeTech. Any reproduction of EdgeTech-supplied software or file sharing is strictly prohibited.

EdgeTech © 2018 - 2019. All rights reserved.

Microsoft® and Windows® are registered trademarks of Microsoft Corporation.

Storm Case™ and Hardigg™ are trademarks of Pelican.

HYPACK® and HYSWEEP® are registered trademarks of Hypack, Inc.

ATTENTION – READ THIS FIRST!

Warnings, Cautions, and Notes

Where applicable, warnings, cautions, and notes are provided in this manual as follows:

WARNING!

Identifies a potential hazard that could cause injury or death.

CAUTION!

Identifies a potential hazard that could damage equipment or data.

NOTE: Recommendations or general information that is particular to the material being presented.

All personnel involved with the installation, operation, or maintenance of the equipment described in this manual should read and understand the warnings and cautions provided below.

CAUTION!

This equipment contains devices that are extremely sensitive to static electricity. Therefore, extreme care should be taken when handling them. Normal handling precautions involve the use of anti-static protection materials and grounding straps for personnel.

WARNING!

High Voltage may be present in all parts of the system. Therefore, use caution when the electronics are removed from their containers for servicing.

CAUTION!

Operation with improper line voltage may cause serious damage to the equipment. Always ensure that the proper line voltage is used.

HARDWARE VARIATIONS AND COMPATIBILITY

The 6205s Bathymetry & Side Scan System contains both standard and proprietary hardware. At times, EdgeTech may change the standard components due to their availability or performance improvements. Although the component manufacturers—along with their models and styles—may change from unit to unit, replacement parts will generally be interchangeable.

EdgeTech will make every effort to see that replacement components are interchangeable and use the same software drivers (if applicable). At times, however, direct replacements may not exist. When this happens, EdgeTech will provide the necessary drivers with the replacement part, if applicable.

EdgeTech may also change certain hardware per customer requirements. Therefore, portions of this manual, such as parts lists and test features, are subject to change. These sections should be used for reference only. When changes are made that affect system operation, they will be explicitly noted. Also, some options and features may not be active in the customer's unit at time of delivery. Upgrades will be made available when these features are implemented.

Contact [EDGE TECH CUSTOMER SERVICE](#) with any questions relating to compatibility.

ABOUT THIS DOCUMENT

We, the employees at EdgeTech, would like to thank you for purchasing a 6205s system. At EdgeTech, it is our policy to provide high-quality, cost-effective products and support services that meet or exceed your requirements. We also strive to deliver them on-time, and to continuously look for ways to improve them. We take pride in the products we manufacture and want you to be entirely satisfied with your equipment.

Purpose of this Manual

The purpose of this manual is to provide the user with information on the setup and use of EdgeTech's 6205s Bathymetry & Side Scan System. Although this manual encompasses the latest operational features of the 6205s, some features may be periodically upgraded. Therefore, the information in this manual is subject to change and should be used for reference only.

Liability

EdgeTech has made every effort to document the 6205s Bathymetry & Side Scan System in this manual accurately and completely. However, EdgeTech assumes no liability for errors or for any damages that result from the use of this manual or the equipment it documents. EdgeTech reserves the right to upgrade features of this equipment, and to make changes to this manual, without notice at any time.

Revision History

REVISION	DESCRIPTION	DATE	APPROVAL
A	Release to Production	10/31/2018	JF
B	Updated to reflect DISCOVER Bathymetry Updates	1/4/2019	JF

WARRANTY STATEMENT

All equipment manufactured by EdgeTech is warranted against defective components and workmanship for a period of one year after shipment. Warranty repair will be done by EdgeTech free of charge.

Shipping costs are to be borne by the customer. Malfunction due to improper use is not covered in the warranty, and EdgeTech disclaims any liability for consequential damage resulting from defects in the performance of the equipment. No product is warranted as being fit for a particular purpose, and there is no warranty of merchantability. This warranty applies only if:

- i. The items are used solely under the operating conditions and in the manner recommended in Seller's instruction manual, specifications, or other literature.
- ii. The items have not been misused or abused in any manner, nor have repairs been attempted thereon without the approval of **EDGETECH CUSTOMER SERVICE**.
- iii. Written notice of the failure within the warranty period is forwarded to Seller and the directions received for properly identifying items returned under warranty are followed.
- iv. The return notice authorizes Seller to examine and disassemble returned products to the extent Seller deems necessary to ascertain the cause for failure.

The warranties expressed herein are exclusive. There are no other warranties, either expressed or implied, beyond those set forth herein, and Seller does not assume any other obligation or liability in connection with the sale or use of said products. Any product or service repaired under this warranty shall be warranted for the remaining portion of the original warranty period only.

Equipment not manufactured by EdgeTech is supported only to the extent of the original manufacturer's warranties.

SOFTWARE SERVICE OVERVIEW

EdgeTech provides software services free of charge. This software agreement does not address customer-specified modifications or enhancements. These services may be ordered separately. Furthermore, EdgeTech software upgrades are meant for the sole use of EdgeTech customers. Any reproduction of EdgeTech-supplied software or file sharing is strictly prohibited.

Software Updates and Enhancements

EdgeTech customers can download new software releases with all modifications and enhancements from the EdgeTech FTP site (in the future, it will be available on the main company website). Major software issues, should they occur, will be reported directly to the customer. New software releases consist of the following:

- Software enhancements that are not on the price list
- Software fixes and changes
- Product integration
- Documentation updates to on-line help
- Tests for compatibility with other modules

Software patches consist of software that has undergone the following:

- Minor software enhancements
- Software fixes and changes

EdgeTech customers are entitled to contact **EDGE TECH CUSTOMER SERVICE** by telephone, facsimile, or e-mail to report a difficulty, discuss a problem, or to receive advice on the best way to perform a task. When contacted, **EDGE TECH CUSTOMER SERVICE** will do the following:

- Respond within 24 hours via Telephone, Facsimile, and E-mail Support
- Immediately attend to serious problems affecting operations
- Attempt to find an immediate work-around

RETURNED MATERIAL AUTHORIZATION

Prior to returning any equipment to EdgeTech, a Returned Material Authorization (RMA) Number must be obtained from **CUSTOMER SERVICE**.

RMA Purpose

The RMA Number identifies returned equipment when it arrives at our receiving dock and enables tracking while at our facility. Refer to RMA number on all documentation and correspondences.

All returned materials must be shipped prepaid. Freight collect shipments will not be accepted. All equipment should be adequately insured for shipping, but equipment belonging to EdgeTech must be insured for full value.

If there is more than one item per consignment, include a packing with the shipment. An invoice can double as a packing slip only when the contents are clearly numbered and identified on the invoice.

CAUTION! Never attempt to ship a Portable Topside in its Storm Case™ alone. Although rugged, these cases are not intended to be used as shipping containers and the delicate internal components could be damaged. Shipping in this manner will void any warranties.

NOTE: All shipping charges shall be the responsibility of the customer, unless under warranty, as EdgeTech will pay for return shipping.

NOTE: For International Shipments valued over \$1000, the following Shipper's oath must be sent with the invoice.

Shipper's Oath:

"I, _____, declare that the articles herein specified are the growth, produce, or manufacture of the United States; that they were exported from the United States from the port of _____, on or about _____; that they are returned without having been advanced in value or improved in condition by any process of manufacture or any other means; and that no drawback, or allowance has been paid or admitted hereof."

Signed _____

CUSTOMER SERVICE

Customer service personnel at EdgeTech are always eager to hear from users of our products. Your feedback is welcome and is a valuable source of information that we use to continually improve these products. Therefore, we encourage you to contact EdgeTech Customer Service to offer any suggestions or to request technical support:

NOTE: Have your system Serial Number available when contacting Customer Service.

E-mail: service@edgetech.com

Mail: 4 Little Brook Road
West Wareham, MA 02576

Telephone: (508) 291-0057

Facsimile: (508) 291-2491

**24-Hour Emergency
Technical Support Line:** (508) 942-8043

For more information go to www.EdgeTech.com.

COMPANY BACKGROUND

EdgeTech (formerly EG&G Marine Instruments) traces its history in underwater data acquisition and processing back to 1966. EdgeTech has designed, developed, and manufactured products, instruments, and systems for the acquisition of underwater data—including marine, estuarine, and coastal applications—for over 50 years.

The company has responded to the needs of the scientific, Naval, and offshore communities by providing equipment—such as sub-bottom profilers, side scan sonar, acoustic releases, USBL positioning systems, and bathymetric systems—that have become standards in the industry.

EdgeTech has also consistently anticipated and responded to future needs through an active research and development program. Current efforts are focused on the application of cutting-edge CHIRP and acoustic technology.

TABLE OF CONTENTS

ATTENTION – READ THIS FIRST!	iii
Warnings, Cautions, and Notes.....	iii
HARDWARE VARIATIONS AND COMPATIBILITY	iv
ABOUT THIS DOCUMENT	v
Purpose of this Manual	v
Liability	v
Revision History	v
WARRANTY STATEMENT	vi
SOFTWARE SERVICE OVERVIEW	vii
Software Updates and Enhancements.....	vii
RETURNED MATERIAL AUTHORIZATION	viii
RMA Purpose	viii
CUSTOMER SERVICE	ix
COMPANY BACKGROUND	x
TABLE OF CONTENTS	xi
LIST OF FIGURES	xiv
LIST OF TABLES	xvi
SECTION 1: OVERVIEW	1-1
1.1 Applications.....	1-2
1.2 Options.....	1-2
1.3 Main System Components	1-2
1.4 DISCOVER Software.....	1-3
1.4.1 Third-Party Software	1-3
1.5 Optional Equipment.....	1-3
1.5.1 Adaptor Flange.....	1-3
SECTION 2: SYSTEM DESCRIPTION	2-4
2.1 The 6205s Sonar Head	2-4
2.1.1 Mounting Plate	2-6
2.1.2 Housing	2-7
2.1.3 Sonar Processor	2-7

2.1.4 Sound Velocity Sensor.....	2-7
2.1.5 Sonar Arrays.....	2-9
2.1.6 Acoustic Center.....	2-9
SECTION 3: SPECIFICATIONS	3-1
3.1 Physical Specifications	3-1
3.2 Acoustic Specifications.....	3-1
3.3 Power Requirements	3-2
3.4 Environmental Specifications.....	3-3
3.5 Topside Specifications.....	3-3
3.6 The 6205s Topside Sonar Interface Box.....	3-4
3.6.1 6205s-R Rack Mount Topside Interface	3-5
3.6.2 6205s-P Portable Topside Interface.....	3-6
3.6.3 Topside Computer Requirements Specifications.....	3-7
3.7 Deck Cable.....	3-8
3.8 Mechanical Drawings.....	3-8
SECTION 4: CONNECTIONS AND FORMATS.....	4-1
4.1 Data Formats.....	4-1
4.2 System Connections and Data Flow.....	4-2
4.2.1 Ethernet LAN Connections.....	4-2
4.2.2 Serial Port Connections.....	4-3
4.2.3 Hardware Connectivity	4-3
4.2.3.1 Serial Port Configuration Examples	4-4
4.2.4 Sonar Data Flow	4-5
4.3 Topside Provided Isolation.....	4-7
SECTION 5: INSTALLATION.....	5-1
5.1 Unpacking and Inspecting.....	5-1
5.2 Sonar Head Installation.....	5-1
5.2.1 Over-the-Bow Deployment.....	5-2
5.2.2 Over-the-Side Deployment	5-3
5.3 Positioning the Topside Interface Box	5-3
5.4 Topside Connections.....	5-4
5.5 Field Exchangeable Frequency Operations.....	5-5

Tools.....	5-5
SECTION 6: CONNECT TO SONAR	6-1
6.1 Connecting to Sonar via Remote Desktop	6-1
6.1.1 Connecting with the 6205s-R.....	6-1
6.1.2 Connecting with the 6205s-P	6-2
6.2 Confirming Supporting Data is Present.....	6-3
SECTION 7: MAINTENANCE.....	7-1
SECTION 8: TROUBLESHOOTING	8-1
8.1 Troubleshooting the SV Sensor.....	8-1
8.2 Configuring Auxiliary Sensors for Redundant Information.....	8-4
8.2.1 Two Different Sensors Supplying the Same Message.....	8-4
8.2.2 Two Sensors Output Same Information with Different Messages	8-6
APPENDIX A: CONFIGURING COM PORTS.....	A-1
A.1 One Sensor.....	A-1
A.2 Two Sensors	A-6
A.3 Three Sensors	A-9
A.4 UDP Connections	A-12
A.5 POSMV Configuration	A-13
APPENDIX B: SOFTWARE	B-1
B.1 DISCOVER BATHYMETRIC.....	B-1
B.2 Third Party Software	B-1
B.2.1 HYPACK	B-1
B.2.2 SonarWiz.....	B-1
B.2.3 QINSy	B-2
B.2.4 CARIS.....	B-2
B.2.5 EIVA NaviSuite	B-2
APPENDIX C: SYSTEM RESTORE.....	C-1

LIST OF FIGURES

Figure 1-1: The 6205s and the Optional Adaptor Flange	1-3
Figure 2-1: 6205s Sonar Head Components	2-5
Figure 2-2: The Mounting Plate	2-6
Figure 2-3: The Optional Adaptor Flange Installed onto the Mounting Plate	2-6
Figure 2-4: 6205s Electronics Housing and Arrays Installed	2-8
Figure 2-5: Acoustic Center Location in X, Y, and Z and Bolt Pattern of Standard 6205s – 0019604	2-10
Figure 2-6: Acoustic Center Location in X, Y, and Z Dimensions and Bolt Pattern with Adaptor Flange – 0021206	2-11
Figure 3-1: Rack Mount Topside	3-5
Figure 3-2: 6205s-P Portable Topside	3-6
Figure 3-3: 6205s-P Portable Topside Interface Box, Side View	3-7
Figure 3-4: 6205s Exploded View	3-9
Figure 3-5: 6205s Exploded View with Adaptor Flange	3-10
Figure 3-6: 6205s Transducer.....	3-11
Figure 3-7: 6205s Array Color Codes Diagram	3-12
Figure 3-8: 6205s Wiring Diagram – 0019627	3-13
Figure 4-1: 6205s-R Rack Mount Topside Interface Connections.....	4-3
Figure 4-2: Sonar Data Flow.....	4-5
Figure 4-3: Chevron Pattern Noise in a Cropped Portion of Discover Bathymetric	4-7
Figure 5-1: 6205s Deployment, Option 1 – Over-the-Bow	5-2
Figure 5-2: 6205s Deployment, Option 2 – Over-the-Side	5-3
Figure 5-3: Unit on Stable Platform	5-6
Figure 5-4: Removing the Cap Screws.....	5-6
Figure 5-5: Top Housing and Deck Cable Removed	5-7
Figure 5-6: Remove the Center Bracket.....	5-7
Figure 5-7: Remove the Portion of the Shell ‘EdgeTech’ and the Logo	5-8
Figure 5-8: The Disconnected Bathymetry and Side Scan Sonar Cables.....	5-8
Figure 5-9: Remove the [6] Cap Screws	5-9
Figure 5-10: All Cap Screws Removed.....	5-9
Figure 5-11: Remove the Existing Transducer	5-9
Figure 5-12: Mount the New Transducer.....	5-10
Figure 6-1: Manual Remote Desktop Credentials for Customer Supplied Computer	6-1

Figure 6-2: Sonar 192.9.0.101 Remote Desktop Connection Window	6-2
Figure 6-3: Sonar 192.9.0.101 Remote Desktop Connection Window	6-3
Figure 6-4: Serial Port Information Window.....	6-4
Figure 6-5: System Status Window	6-5
Figure 8-1: No Sound Velocity on Port 4.....	8-1
Figure 8-2: Sonar 192.9.0.101 Remote Desktop Connection Window	8-1
Figure 8-3: Closing the Sonar.exe Application	8-2
Figure 8-4: Connecting to COM4 using TeraTerm	8-2
Figure 8-5: COM4 Port Settings	8-3
Figure 8-6: Scrolling SV Data in Sonar.exe	8-4
Figure 8-7: Configuration Menu.....	8-5
Figure 8-8: Auxiliary Sensors.....	8-5
Figure 8-9: Sonar Control Tab	8-6
Figure 8-10: SonarSerial.ini	8-7
Figure A-1: Sonar Remote Desktop Application, Main Screen	A-2
Figure A-2: Sonar Remote Desktop, Shortcut to EdgeTech Folder	A-2
Figure A-3: Finding the SonarSerial.ini File	A-2
Figure A-4: SonarSerial.ini File	A-3
Figure A-5: Diagnostic Window, Reporting Ports Inactive Error.....	A-3
Figure A-6: Rebooting Sonar from the Main Screen.....	A-4
Figure A-7: Checking Serial Port Information	A-5
Figure A-8: Checking Sensor Status.....	A-5
Figure A-9: Closing the System Status Window	A-6
Figure A-10: SonarSerial.ini File	A-7
Figure A-11: Checking Sensors' Usages.....	A-8
Figure A-12: All Sensors Set	A-9
Figure A-13: Checking all COM Ports	A-11
Figure A-14: UDP Configuration Example	A-12
Figure A-15: POSMV UDP Configuration.....	A-13
Figure A-16: SonarConfig.ini Example.....	A-14
Figure A-17: TimeSyncSource Keyword Adjustments.....	A-14

LIST OF TABLES

Table 3-1: Physical Specifications3-1

Table 3-2: Acoustic Specifications.....3-2

Table 3-3: Power Requirements3-2

Table 3-4: Environmental Specifications.....3-3

Table 3-5: 6205s Topside Interface Specifications.....3-3

SECTION 1: OVERVIEW

The EdgeTech 6205s is a fully integrated Swath Bathymetry and Dual Frequency Side Scan Sonar System that uses multiple receive elements, and one discrete transmit element, to produce real time, high resolution, side scan imagery, and three-dimensional maps of the seafloor. The 6205s overcomes the limitations of Multi Beam Echo Sounders (MBES) and Interferometric systems in shallow water by using EdgeTech's unique Multi-Phase Echo Sounder (MPES) technology. This Hybrid approach combines both Beamforming and Phase Discrimination techniques to determine each sounding along the seafloor. With the integration of EdgeTech's Full Spectrum® CHIRP technology, the 6205s exceeds IHO SP-44, NOAA, and USACE specifications for Feature Detection and Bathymetric Point Data Uncertainty.

EdgeTech's MPES technology enables the 6205s to produce wider and cleaner swath (over 200°) than current technologies, resulting in superior coverage enabling faster and safer survey completion. At the same time, the 6205s rejects multipath effects, reverberation, and acoustic noise commonly encountered in shallow water environments.

The 6205s provides Dual Frequency Side Scan Sonar, operating at 230/550 kHz, 550/850kHz or 550/1600 kHz, while the Side Scan imagery is collected simultaneously on both frequencies. The Bathymetry operates at either 230kHz or 550kHz.

Additionally, EdgeTech's latest 2205 Electronics and Modular Arrays are utilized in the 6205s, resulting in an extremely lightweight design, which is required for shallow water applications and vessels of opportunity. The 2205 electronics and arrays are mounted onto a streamline body that is deployed over-the-bow or side of a survey vessel. Sonar data is transferred from the transceiver to the processing unit on board via an Ethernet network interface.

The standard configuration for the 6205s includes an integrated Sound Velocity Sensor, and interfaces to most Third-Party acquisition and processing software packages, and to standard DGPS/RTK systems, Altimeters, GPS, MRU, SVP, Gyros, and INS—together offering a powerful and versatile acquisition system that is suitable for many different applications.

The 6205s has a variety of features, including:

- Next generation MPES technology
- Unrivaled Swath coverage in shallow water, when compared to other single head systems
- Swath sectors of up to 200°
- Co-registered Dual Frequency Side Scan and Single Frequency Bathymetry
- Superior multipath rejection
- IHO SP-44 Special Order compliant
- Equidistant and Equiangle output options
- Comes with EdgeTech's Discover Bathymetric Sonar Control Software
- Motion tolerant Side Scan
- Universal MRU Mounting Plate
- Field swappable Transducers (Bathymetric Electronics can swap between 230kHz or 520kHz)

1.1 Applications

The 6205s next generation Swath Bathymetry & Side Scan Sonar has many potential applications, a few of which include:

- Shallow Water Hydrographic Surveys
- Benthic Habitat Mapping
- Nautical Charting
- Military Rapid Environmental Assessments (REA)
- Route Surveys
- Dredging Operations
- Marine Debris Search
- Port & Harbor Security

1.2 Options

The 6205s is available in several standard frequency configurations:

- 230 / 550 kHz Dual Frequency Side Scan with 230 kHz Bathymetry Data
- 230 / 550 kHz Dual Frequency Side Scan with 550 kHz Bathymetry Data
- 550 / 850 kHz Dual Frequency Side Scan with 550 kHz Bathymetry Data
- 550 / 1600 kHz Dual Frequency Side Scan with 550 kHz Bathymetry Data

The modular design of the 6205s allows for multi-frequency bathymetry options in a single sonar head. The field exchangeable array capability allows both shallow and deep-water operations but is only available with 230 / 550 kHz Side Scan systems. The difference between the different frequency arrays is identified by color. Refer to **FIGURE 3-9** for frequency differentiations by color.

1.3 Main System Components

The following components come standard with the 6205s System:

- **6205s SWATH BATHYMETRY AND SIDE SCAN SONAR HEAD**
- **DECK CABLE** 20m (65ft)
- **SOUND VELOCITY SENSOR (SVS)** [Mounted to Connector Endcap]
- Large Pelican Hardigg™ Shipping Case
- **6205s-R RACK MOUNT INTERFACE BOX**
- DISCOVER BATHYMETRIC Acquisition Software
- 6205s Tool Kit

1.4 DISCOVER Software

EdgeTech's DISCOVER Bathymetric Software Acquisition package provides a way to control, store, and display the Bathymetry and Dual Frequency Side Scan Sonar data. For more information on the DISCOVER BATHYMETRIC software, refer to its manual (0014878).

1.4.1 Third-Party Software

EdgeTech has approved a small number of Third-Party Topsides for acquisition and processing of Bathymetry and Side Scan data. Currently, Hypack, SonarWiz, and QINSy software packages have been approved, but work continues to expand the number of topsides. CARIS HIPS/SIPS supports our native JSF files for post processing.

For questions on Third-Party Interfacing with DISCOVER Bathymetry, refer to [THIRD PARTY SOFTWARE](#). Contact [EDGETECH CUSTOMER SERVICE](#) for updates.

1.5 Optional Equipment

- [ARRAYS FOR FIELD EXCHANGEABLE FREQUENCY OPERATIONS](#)
- [6205s-P PORTABLE TOPSIDE WITH LAPTOP](#)
- Adaptor Flange
- Spares Kit

1.5.1 Adaptor Flange

The Adaptor Flange mounts to the existing Mounting Plate and is designed for static pole-mounting operations. The Adaptor Flange is available if the standard 6205s hole pattern will not mate to the customer's available static pole-mount. The Adaptor Flange is attached to the [MOUNTING PLATE](#). Refer to [FIGURE 2-2](#) for visual depiction of the Adaptor Flange.

Refer to [FIGURE 3-9](#) and [FIGURE 3-10](#) for a comparison of bolt patterns.



Figure 1-1: The 6205s and the Optional Adaptor Flange

SECTION 2: SYSTEM DESCRIPTION

The complete 6205s system consists of a Swath Bathymetry and Side Scan Sonar Head and a Topside Interface Box. This section describes the 6205s System main components and lists its specifications.

2.1 The 6205s Sonar Head

The 6205s Swath Bathymetry and Side Scan Sonar Head is available in a variety of frequency options:

- 230 / 550 kHz Dual Frequency Side Scan with 230 kHz Bathymetry Data
- 230 / 550 kHz Dual Frequency Side Scan with 550 kHz Bathymetry Data
- 550 / 850 kHz Dual Frequency Side Scan with 550 kHz Bathymetry Data
- 550 / 1600 kHz Dual Frequency Side Scan with 550 kHz Bathymetry Data

The frequency sets listed above were chosen to provide optimum results for any given water depth up to 200m (660ft) below the transducer. The 6205s is for water depths between 5m – 50m (15ft – 164ft). Optimal Frequency depends on survey requirements.

To mitigate frequency tradeoffs, EdgeTech has designed the 6205s Sonar Head with Field Exchangeable Arrays whereby the Bathymetry frequency can be switched from the low frequency channel to the high frequency channel or vice versa. However, this feature only exists on the 230 kHz/550 kHz models.

The 6205s Swath Bathymetry and Side Scan Sonar Head comes standard with a Sonar Processor, Port and Starboard Sonar Arrays, a Sound Velocity Sensor (SVS), and Housing. These components are demonstrated in [FIGURE 2-1](#).

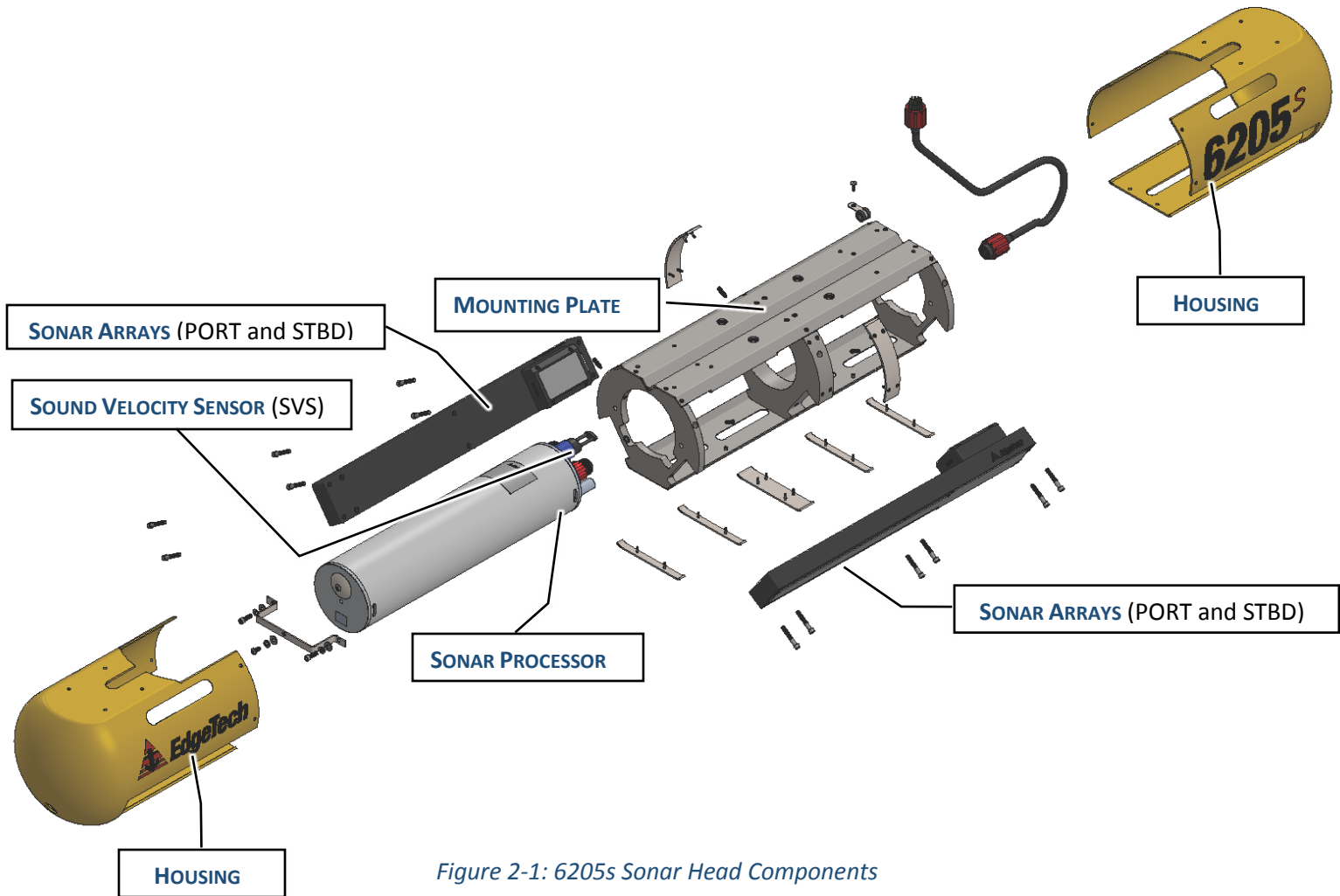

Figure 2-1: 6205s Sonar Head Components

NOTE: The terms used in **Figure 2-1** are referenced throughout this manual.

2.1.1 Mounting Plate

The 6205s Mounting Plate is made of stainless steel and was designed with a variable bolt pattern to secure the system to several different deployment mechanisms, thereby cutting back on installation and mobilization time. The variable bolt pattern is shown in **FIGURE 2-3**.

EdgeTech advises mounting the 6205s Sonar Head to the bow of a survey vessel. By placing the system at the bow, the sonar should be far enough away from most interference, such as hull echoes, propeller noise, and wake.



Figure 2-2: The Mounting Plate

Refer to **FIGURE 2-5** and **FIGURE 2-6** for a comparison of bolt patterns.

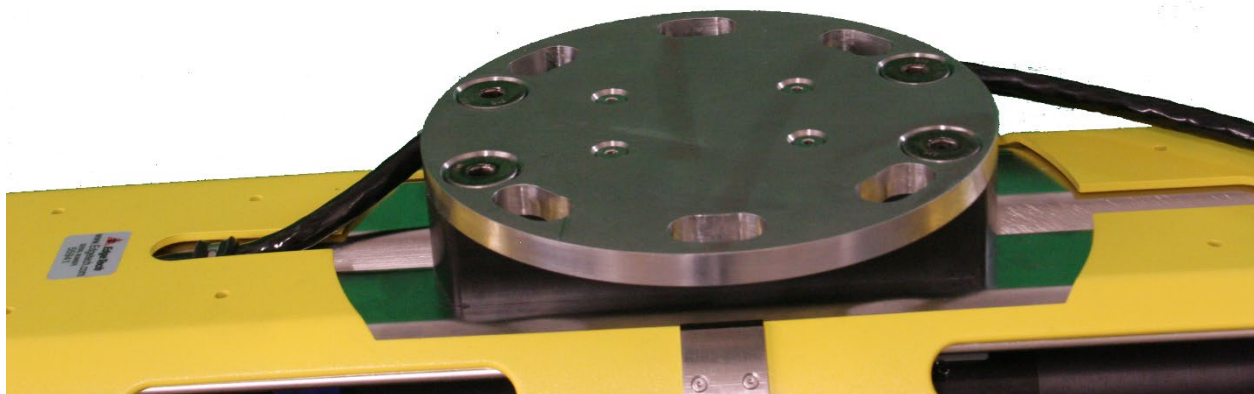

Figure 2-3: The Optional Adaptor Flange Installed onto the Mounting Plate

2.1.2 Housing

The 6205s shells are thermoformed Polycarbonate (PC). The Internal Frame is made of electropolished 316 stainless-steel and Acetal Homopolymer (Delrin). The housing supplies a streamline body for efficient underwater maneuvers rated up to 12 knots, while protecting the SVS, arrays, and deck cable connections.

NOTE: Although the 6205s can handle transit up to 12 knots, survey speeds should be constrained to 4-5 knots or less. However, EdgeTech recommends removing the Sonar Head from the water during transit above 7-8 knots.

2.1.3 Sonar Processor

The 6205s Sonar Processor has a built-in Windows 7 Embedded PC. The main firmware installed on the embedded PC is called Sonar.exe, which controls the sonar's hardware and performs specific functions, such as signal processing and time synchronization of the acquired data.

2.1.4 Sound Velocity Sensor

The 6205s Sonar Head has a flooded section that is used to house an AML Sound Velocity Sensor (SVS), which provides a response time of 47 μ s, a resolution of 0.001 m/s, and a theoretical accuracy of ± 0.025 m/s. A closer look at the SVS is presented in [FIGURE 2-4](#).

EdgeTech recommends collecting a sound velocity profile, especially in the area where you collect test data. The water being operated in likely does not have a uniform sound velocity, and depending on how drastic the profile is, a depth error as large as 1.6 m has been observed.

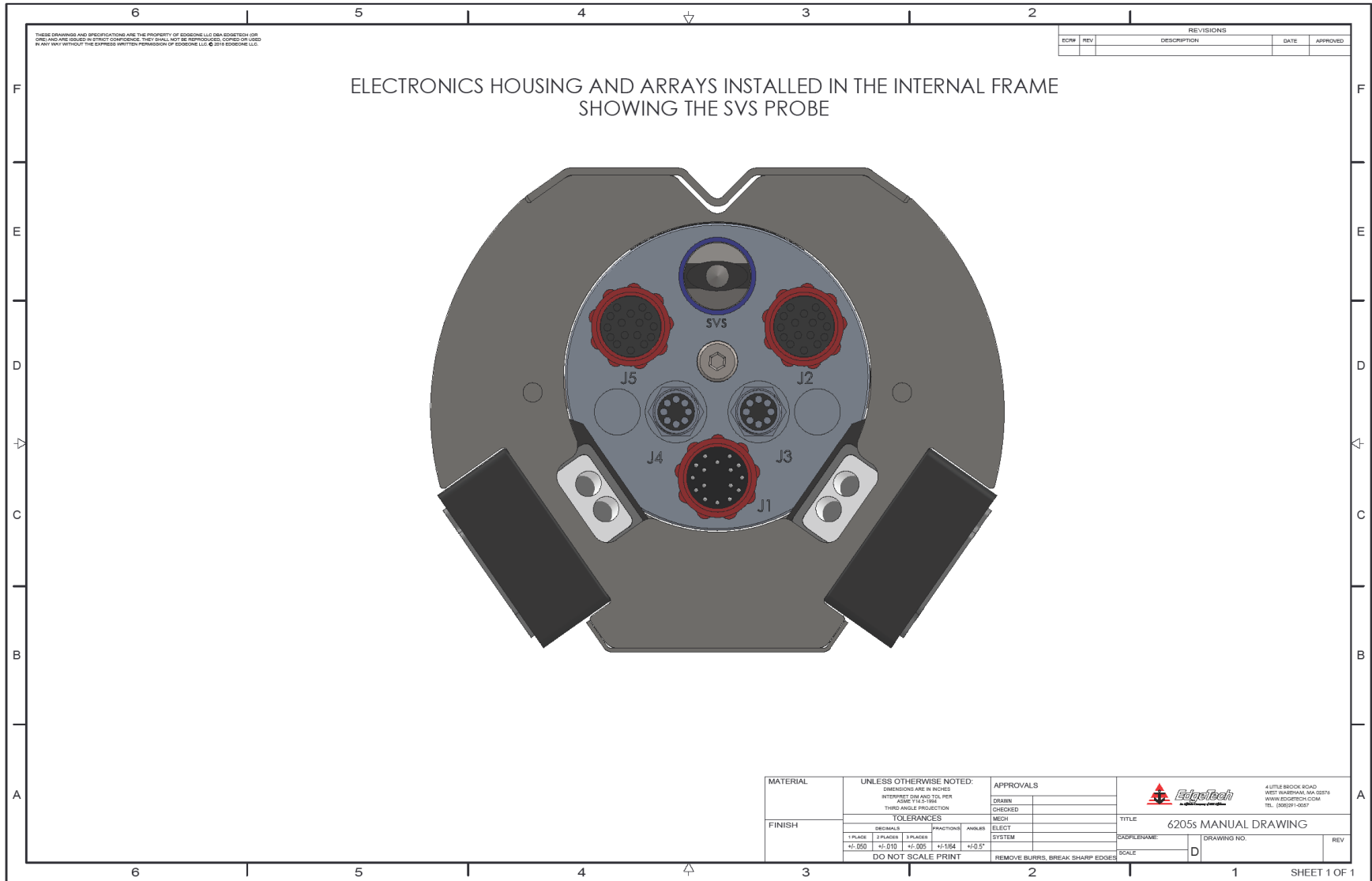

Figure 2-4: 6205s Electronics Housing and Arrays Installed

2.1.5 Sonar Arrays

The 6205s provides single frequency Bathymetry and Simultaneous Dual Frequency Side Scan Sonar.

The Side Scan Sonar operates at 230/550 kHz, 540/850, or 550/1600 kHz and collects simultaneously on both frequency channels. Bathymetry is obtained on either the 230 kHz or the 550 kHz. The 6205s utilizes two arrays (port and starboard) to map the seafloor much like a Dual Head Multibeam System. Each 6205s Array is constructed using 10 independent longitudinal PZT elements and two multi-segment PZT strings. The two multi-element strings (one per Side Scan Frequency) are used for the transmit function and as a full resolution side scan receiver. The remaining 10 elements make up approximately half-wavelength spaced array of sensors for its bathymetry receiver.

2.1.6 Acoustic Center

The individual Acoustic Centers of each Array (port and starboard) converge at a single point along the centerline of the 6205s Sonar Head. Therefore, when entering sonar head offsets into the Third-Party acquisition and processing software, the port and starboard array offsets (or sometimes referred to as Sonar Head 1 and Sonar Head 2, respectively) are identical in all dimensions.

The EdgeTech convention for X, Y, and Z is:

- X is positive to starboard
- Y is positive forward
- Z is positive down

Remember that the individual Acoustic Centers for both port and starboard converge on the centerline (or $X = 0$).

NOTE: The Acoustic Center along the Y axis is different for the 230kHz model than the 550kHz model.

For a larger representation of [FIGURE 2-5](#) and [FIGURE 2-6](#)

SECTION 2: SYSTEM DESCRIPTION

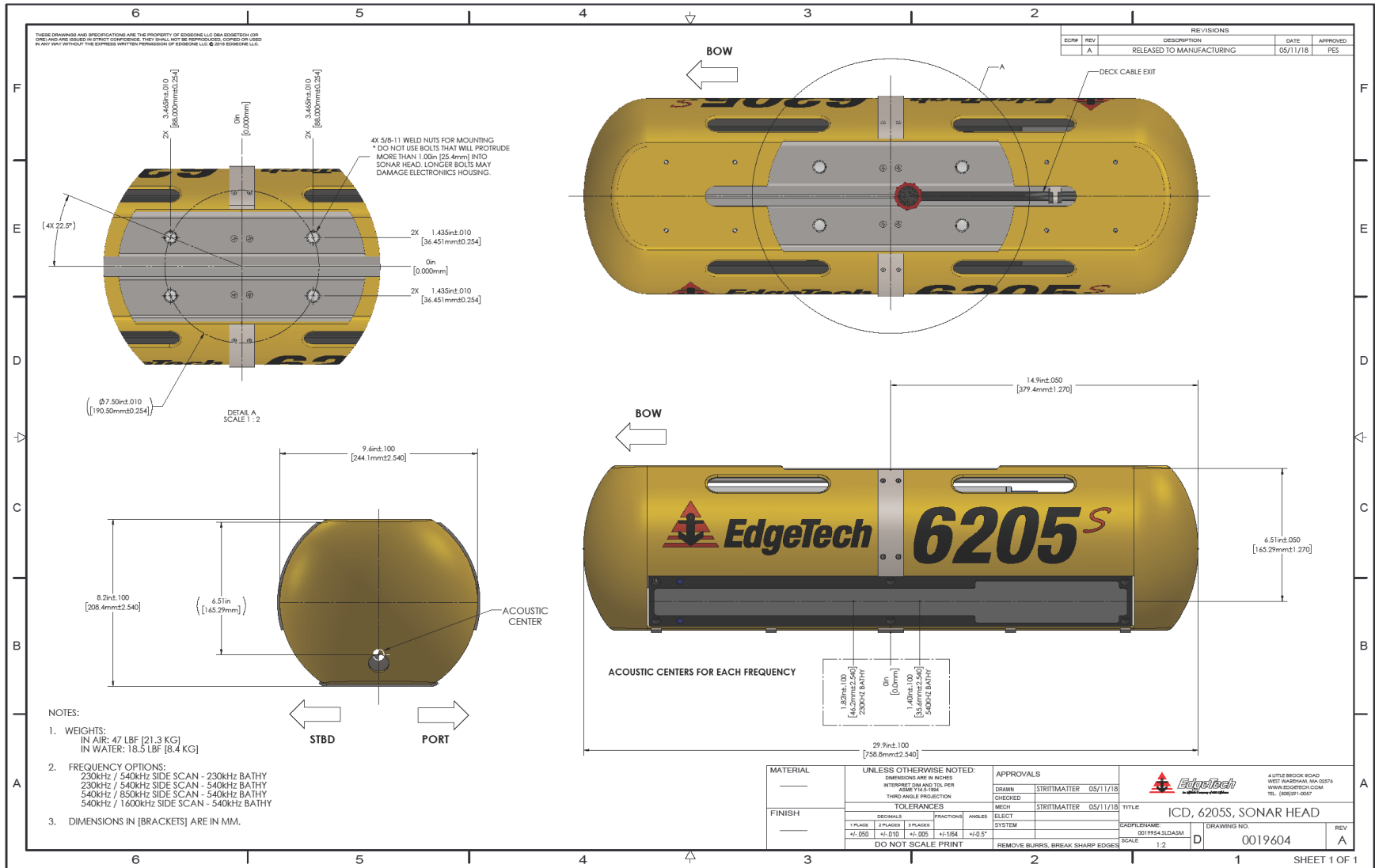

Figure 2-5: Acoustic Center Location in X, Y, and Z and Bolt Pattern of Standard 6205s – 0019604

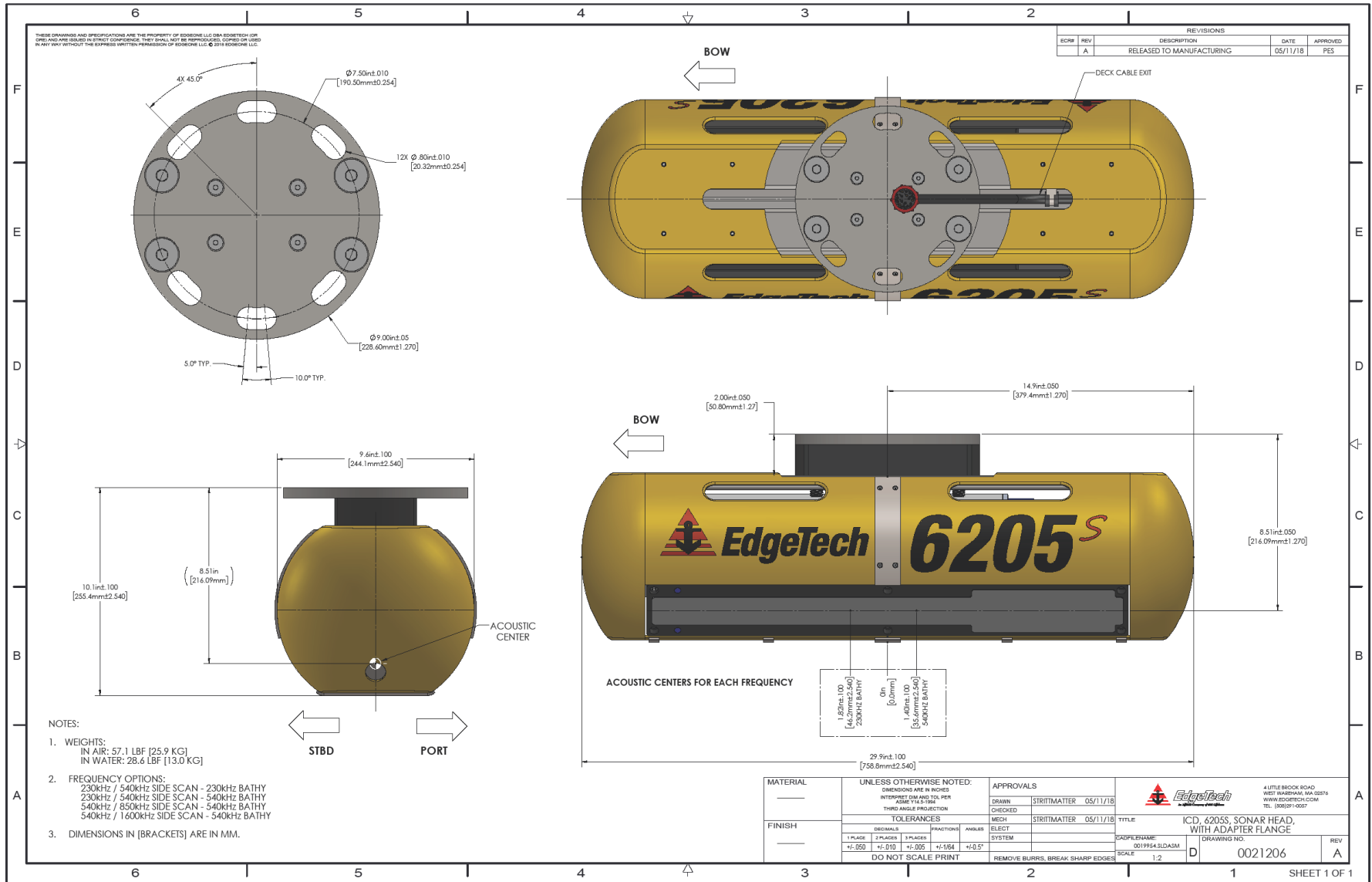

Figure 2-6: Acoustic Center Location in X, Y, and Z Dimensions and Bolt Pattern with Adaptor Flange – 0021206

SECTION 3: SPECIFICATIONS

This section details the System Specifications of the 6205.

3.1 Physical Specifications

PHYSICAL	
Size	76.2 L x 21.1 W x 27.9 H cm (30 L x 8.3 W x 11 H in)
Weight	(W/o Adapter Flange): 21.3 kg (47 lbs) (W/ Adapter Flange): 25.9 kg (57.1 lbs)
Construction	Polycarbonate / 316 Stainless Steel Frame
Color	Blue Angels Yellow
Sealing	O-Ring Seal with Purge Valve

Table 3-1: Physical Specifications

3.2 Acoustic Specifications

SONAR HEAD MODEL	230/550 KHZ SS – 230/550 BATHY	550/1600 SS - 550 KHZ BATHY
SIDE SCAN SONAR		
Center Frequency	230/520 kHz	520/1610 kHz
Range (per Side)	225/125 m (738/410 ft)	125/35m (410/115 ft)
Range Resolution	30/15 mm (1.18/0.4 in)	15/6 mm (0.4/0.2 in)
Beam Width Along Track	0.64°/0.47° (2-way)	0.47°/0.2° (2-way)
Depression Angle	35°	35°
SWATH BATHYMETRY		
Center Frequency	230 kHz/520kHz	520 kHz
Maximum Swath	350 m (1148 ft)	150 m (492 ft)
Beam Width Along Track	0.64°/0.47°	0.47°
Ping Repetition Rate (Both Sides Simultaneously)	15 m (16 ft) = 50 Hz 25 m (82 ft) = 30 Hz 50 m (164 ft) = 15 Hz 100 m (328 ft) = 8 Hz 200 m (656 ft) = 4 Hz	5 m (16 ft) = 150 Hz 25 m (82 ft) = 30 Hz 50 m (164 ft) = 15 Hz 100 m (328 ft) = 8 Hz 150 m (492 ft) = 5 Hz
BATHYMETRY		
Sonar Frequency	230 kHz	550 kHz
Beamwidths Across track resolution expressed as a beamwidth at nadir	1° x 0.7°	1° x 0.5°

Max Sounding Depth Dependent on environmental conditions (absorption, reverberation, sea noise)	100 m	50 m		
Max Swath Width Assumes a flat seafloor and dependent on environmental conditions	400 m	200 m		
Max Swath Sector	200°			
Max Number of Soundings	800			
Sounding Patterns	Equidistant and Equiangular			
SIDE SCAN SONAR IMAGERY				
Frequency	230 kHz	550 kHz	850 kHz	1600 kHz
Horizontal Beamwidth (2-way)	0.54°	0.36°	0.29°	0.20°
Range Resolution	30 mm	10 mm	9 mm	6 mm
Max Range Dependent on environmental conditions (absorption, reverberation, sea noise)	250 m	150 m	75 m	35 m
SYSTEM				
Pulse Modulation	CW & FM CHIRP			
Construction	Polycarbonate / 316 Stainless Steel Frame			
Dimensions	208 x 244 x 759 mm (8.1 x 9.6 x 29.8 in)			
Deck Cable Length	20m (Standard)			
Depth Rating	50 m			
Weight (In Air)	19.9 kg (44 lbs)			
Input Voltage	48-60 VDC			
Power (Typical /Max)	55W / 70W			
Data Products	Bathymetry, Backscatter and Side Scan Imagery, and Real Time Uncertainties			

Table 3-2: Acoustic Specifications

3.3 Power Requirements

POWER REQUIREMENTS		
DC Input Range	36-60 VDC (48 VDC Nominal)	36-60 VDC (48 VDC Nominal)

Table 3-3: Power Requirements

3.4 Environmental Specifications

ENVIRONMENT		
Operating Temperature	0°C to 40°C (32°F to 104°F)	0°C to 40°C (32°F to 104°F)
Storage Temperature	-20°C to 60°C (-4°F to 140°F)	-20°C to 60°C (-4°F to 140°F)
Relative Humidity	Operating 0 to 80%, Non-Operating 0 to 100%	Operating 0 to 80%, Non-Operating 0 to 100%

Table 3-4: Environmental Specifications

3.5 Topside Specifications

Detailed specifications for 6205s Topside Interfaces and Sonar Heads are provided in

INTERFACE MODEL	6205S – RACK MOUNT	6205S - PORTABLE
PHYSICALS		
Size	L: 48.3cm x W: 52.1cm x H: 8.9cm (L: 19 x W: 20.5 x H: 3.5)	L: 49.5cm x W: 38.1cm x H: 19.1cm (L: 19.5" x W: 15" x H: 7.5")
Weight	5.4 kg (12 lbs)	13.6 kg (30 lbs)
Construction	Aluminum	Polyethylene/Polyurethane
Interfaces	(1) 1 PPS via BNC (1) Trigger In via BNC (4) 100 BaseT Ethernet Ports (3) Serial RS-232 Ports	(1) 1 PPS via BNC (1) Trigger In via BNC (3) 100 BaseT Ethernet Ports (3) Serial RS-232 Ports
POWER REQUIREMENTS		
Input Power Supply	115/230 VAC Auto-Sensing	115/230 VAC Auto-Sensing
Output Power Supply	60VDC	48VDC
Current Draw	1.40A	1.40A

Table 3-5: 6205s Topside Interface Specifications

3.6 The 6205s Topside Sonar Interface Box

The 6205s Topside Sonar Interface Box has two purposes:

1. To provide power to the Sonar Head
2. To provide a direct link between Sonar Head, any supporting sensors, and Topside Computer.

The Topside Sonar Interface Box delivers power to the system and transmits/receives data via the provided 20m (65ft) Deck Cable and a SubConn 16 pin wet mate connector. The Topside Sonar Interface Box supplies (3) RS232 serial ports to intake Navigation, Heading, and Attitude Data from the supporting sensors and an Ethernet port to communicate with the Topside Computer.

The first two RS232 serial ports are configured for high speed and high accuracy, while the third RS232 serial port is configured for standard serial connections. Typical latencies for the high speed/high accuracy ports are less than 100us, whereas the standard serial port may have up to 100ms. The high-speed ports are unidirectional, data cannot be transmitted from the 6205s to an external device. All three com ports are isolated via a proprietary Signal Conditioning / Isolator board. This ensures noise generated or carried by grounds on the survey vessel do not generate artifacts in the Side Scan and Bathymetry data sets.

The 6205s can receive data from supporting sensors via the Ethernet connection utilizing UDP. Refer to [SUB-SECTION B.4](#) for more information on configuring 6205s for UDP data transfer.

This Topside Sonar Interface Box comes in two forms:

1. **6205s-R RACK MOUNT TOPSIDE INTERFACE** for use with a Customer-supplied computer.
2. **6205s-P PORTABLE TOPSIDE INTERFACE** for use with: Customer-supplied computer or purchased EdgeTech-supplied fully configured Laptop.

Both the 6205s-Portable and 6205s-Rackmount come with a USB which contains manuals and Discover Bathymetry. Optional laptops come preloaded with EdgeTech's DISCOVER BATHYMETRIC Acquisition Software and all Manuals. DISCOVER BATHYMETRIC can also be downloaded from the EdgeTech FTP site. Contact [EDGE TECH CUSTOMER SERVICE](#) for FTP credentials.

3.6.1 6205s-R Rack Mount Topside Interface

The 6205s-R Rack Mount Topside Sonar Interface Box was designed to slide into a 19-in Rack Mount Optima Case. It provides three input/output serial ports, four Ethernet ports, AC power input, On/Off switch, and two BNC connectors that supply an input trigger and 1PPS sync. The three input serial ports act as a dry connection to the sonar head for all ancillary information (i.e. position, attitude, time, etc.), while the four Ethernet ports provide 100Mbps connection from the sonar head to the topside computer. These interfaces are shown in [FIGURE 3-1](#).



Figure 3-1: Rack Mount Topside

The Rack Mount Topside Sonar Interface Box option does not come with a topside computer, this must be supplied by the customer. See the minimum requirements provided in sub-section [3.6.3](#).

If the 6205s-R Rack Mount Topside Interface Box does not turn on, check the on/off switch on the back panel. It is located next to the power plug.

3.6.2 6205s-P Portable Topside Interface

The 6205s-P Portable Topside Interface is a splash proof design of the 6205s-R Rack Mount Interface box. It offers all the same connections to the 6205s Sonar Head for the supporting sensors (i.e. GPS, MRU, etc.) through a series of break out cables. The Portable Topside has an option for a laptop. The laptop is a high-performance PC, running Windows 10 operating system. It also has a Quad Core processor (8 cores) and comes with a 1TB hard drive.

CAUTION!

The laptop's performance changes when running on battery power so ensure the laptop is plugged in when operating the Sonar and acquiring real time Bathymetry and Side Scan Data.



Figure 3-2: 6205s-P Portable Topside



Figure 3-3: 6205s-P Portable Topside Interface Box, Side View

3.6.3 Topside Computer Requirements Specifications

The topside computer must be able to run EdgeTech's DISCOVER BATHYMETRIC Acquisition Software and any additional Third-Party software. To do so, it must include the following minimum requirements:

- Windows 10 Professional Operating System
- Quad-Core Intel Core i7-4900MQ @ 2.8GHz Processor or similar
- 8 GB of Memory (RAM)
- 500GB Hard Drive
- 3 USB Ports
- 1 Ethernet Port
- 1 GB Graphics Card

The 6205s-Portable has an optional Ruggedized GETAC Laptop, preloaded with EdgeTech's DISCOVER Bathymetric Software and all supporting software. The laptop has the specifications below:

- Windows 10 Professional Operating System
- Intel® Core™ i7-8650U vPro 1.9GHz processor with Turbo Boost Technology
- 8 GB of Memory (RAM)
- 1TB Hard Drive
- Intel UHD Graphics 620
- NVIDIA Quadro M2000M (4GB GDDR5)
- 3 USB 3.0 (9-pin)
- 1 USB 2.0 (4-pin)
- 1 Ethernet RJ45 Port
- 1 Mini Display Port 1 HDMI Port

NOTE: The Topside laptop may look and operate like a general-purpose PC, however, installing additional software outside the provided EdgeTech and Bathymetric Third-Party Software is NOT recommended. Installing software other than those supplied can have undesirable effects, such as poor and/or slow performance when acquiring Bathymetry and dual frequency Side Scan data. A list of approved Third-Party packages is provided in [THIRD PARTY SOFTWARE](#).

3.7 Deck Cable

The Deck cable is a 20 meter (65ft) underwater, high speed network data and power cable. Deck cable includes Cat 5e 4-pair stranded conductors that meets or exceeds TIA 568-B and is suitable for 10Base-T and 100Base-T. Deck cable is terminated with a Subconn 16 pin wet mate connector on both ends, has a breaking strength of 545 kg (1200lbs), and provides power and telemetry to 6205s Sonar Head.

CAUTION! DO NOT use Deck Cables for towing.

3.8 Mechanical Drawings

This section contains supporting drawings for the 6205s Swath Bathymetry and Dual Frequency Side Scan Sonar System:

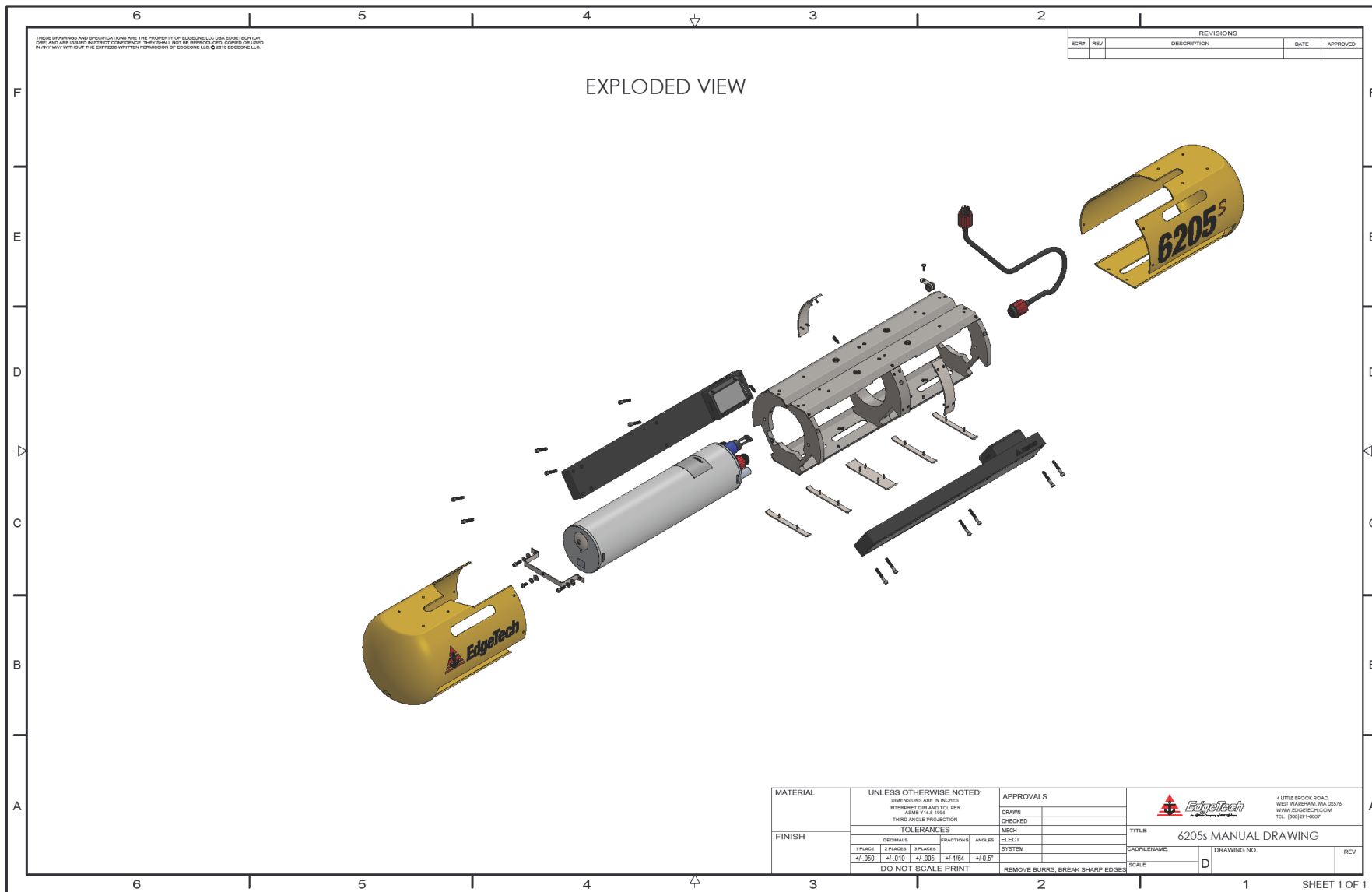

Figure 3-4: 6205s Exploded View

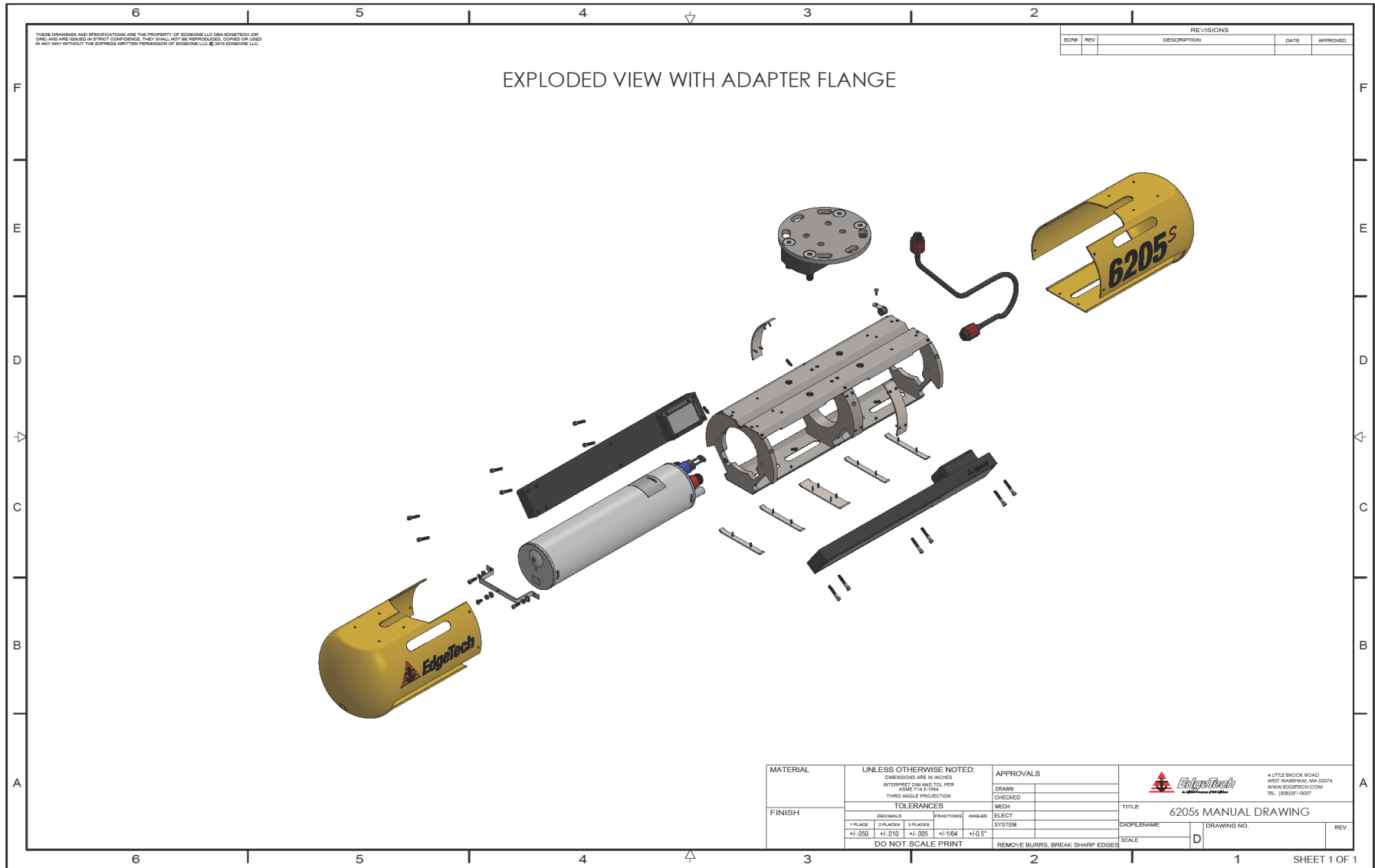

Figure 3-5: 6205s Exploded View with Adaptor Flange

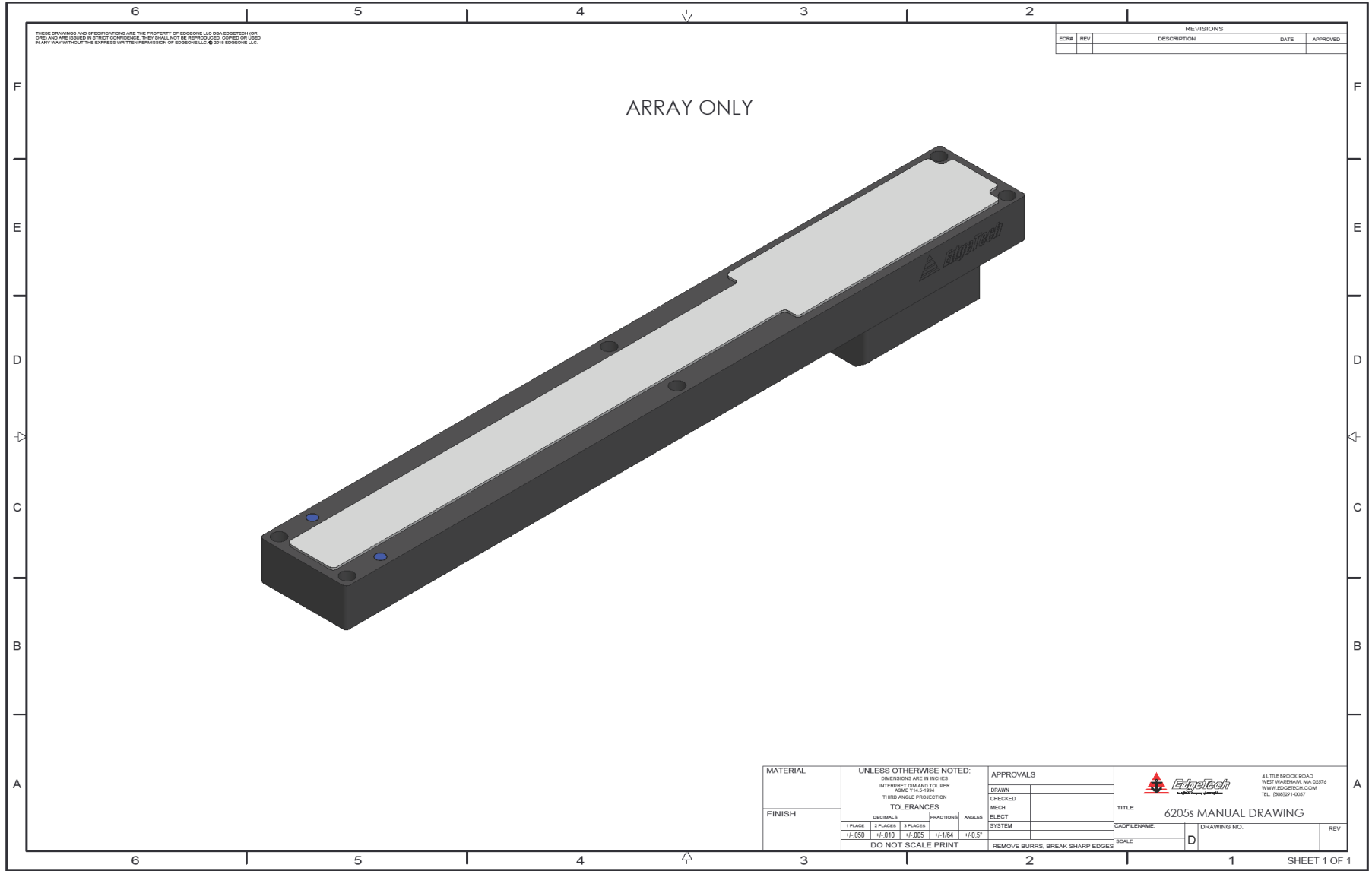

Figure 3-6: 6205s Transducer

The 6205s Arrays have been color coded based on their operating frequency. The color code is shown and described below:



Figure 3-7: 6205s Array Color Codes Diagram

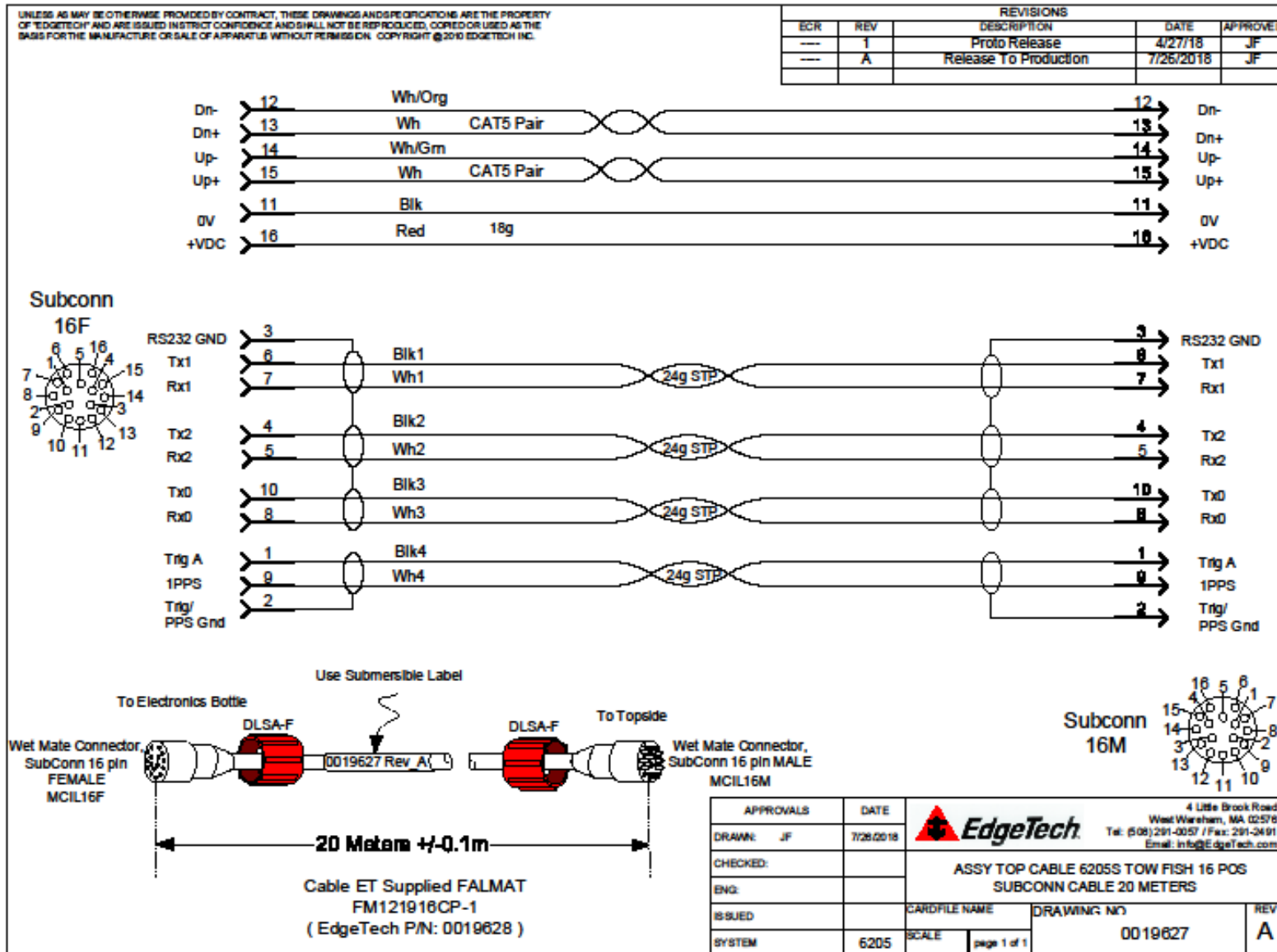

Figure 3-8: 6205s Wiring Diagram – 0019627

SECTION 4: CONNECTIONS AND FORMATS

The 6205s System relies on specific data formats and connections to produce its high-quality images and measurements. This section describes these data formats and connections along with providing diagrams to help the user better understand the hardware and data flow within the system.

4.1 Data Formats

In order to collect valid survey data the following is required to support the survey operations and correct processing of the 6205s Bathymetry and Dual Frequency Side Scan echo data:

- a. GPS Position in NMEA format, latitude and longitude; minimum of 5Hz
- b. Heading data in NMEA format or EM1000 binary format; minimum of 20Hz
- c. Attitude or Roll, Pitch, and Heave data in TSS1 or EM1000 binary format; minimum of 20Hz
- d. Time sync data in NMEA format; minimum of 1Hz

These data may be supplied by 1, 2, or 3 individual sources, and are listed below in order of priority.

- a. **Position Data** – this may be supplied via any of the following NMEA type sentences/messages:
 - i. \$xxGGA
 - ii. \$xxGLL
 - iii. \$xxRMC
 - iv. \$xxGGK ** (Applanix PosMV Format) ** = Non-NMEA standard sentences
 - v. \$PTNL, GGK, ... ** (Trimble Format)
- b. **Heading Data** – this may be input via:
 - i. NMEA, \$xxHDT sentence, OR
 - ii. EM1000 binary format along with attitude data
- c. **Attitude (Roll, Pitch, and Heave) Data** – this may be input via:
 - i. TSS1 format, OR
 - ii. EM1000 binary format
- d. **Time Input** - supported sentences are in order of priority/use
 - i. \$xxZDA
 - ii. \$xxRMC
 - iii. \$xxGGK (derived from data in item a. above)
 - iv. \$xxGGA (only supports time, no date field)
 - v. \$xxGLL (only supports time, no date field)

NOTE: The prefix “\$xx” represents proprietary NMEA message prefix for a specific manufacturer. \$GPGGA, \$GPZDA, etc. are example NMEA output sentences for a Hemisphere GPS.

We recommend you also supply the system with a source of Speed Over Ground in NMEA format (i.e. VTG, minimum of 1Hz) so that the system can correctly compute Along-Track Distance between each ping and display it in DISCOVER BATHYMETRIC Software.

Messages can be sent over ethernet connection via UDP functionality.

4.2 System Connections and Data Flow

The following sub-sections describe the connections and data flow for the 6205s System.

4.2.1 Ethernet LAN Connections

The Ethernet LAN connection from the Sonar Head to the 6205s Topside Interface is made using a physical wired connection via a 40inch extension and the standard 20m (65 ft) Deck Cable. The 6205s Sonar Interface then connects to a Topside Computer via a standard RJ-45 Ethernet plug. The correct IP addresses for the sonar head and topside PC are listed below. The 6205s Sonar Interface then connects to a Topside Computer via a standard RJ-45 Ethernet plug. The correct IP addresses for the sonar head and topside PC are listed below.

- Sonar Head IP Address = 192.9.0.101
- Topside PC IP Address = 192.9.0.99

NOTE: Factory defaults for the 6205s Sonar head IP address is 192.9.0.101 and should not be changed for any reason. The supplied laptop with the 6205s-P portable topside interface will also be preconfigured to 192.9.0.99 on delivery from the factory. Only when the customer supplies their own topside computer that the IP address needs to be set to the address above.

4.2.2 Serial Port Connections

There are three RS-232 serial ports provided on the 6205s Sonar Interface box. COM1 and COM2 have been configured for high speed and high accuracy). COM3 is configured for standard RS-232 serial connections. Typical latencies for the high speed/high accuracy ports are less than 100us, whereas the standard serial port has up to 100ms.

These serial ports are provided to intake the navigation, heading, and attitude (roll, pitch, and heave) data from the supporting sensors. Refer to **CONFIGURING COM PORTS** to configure the COM ports.

If the Rack Mount topside is being utilized, it can serve as a splitter for serial data. The output ports pair with the serial ports located directly above them. These ports are unidirectional.

4.2.3 Hardware Connectivity

FIGURE 3-1 is a block diagram that illustrates interconnections between the 6205s Swath Bathymetry and Dual Frequency Side Scan Sonar Head, the 6205s-R Rack Mount Topside Interface, and all supporting sensors. This illustration gives examples of three possible sensor configurations that are explained below.

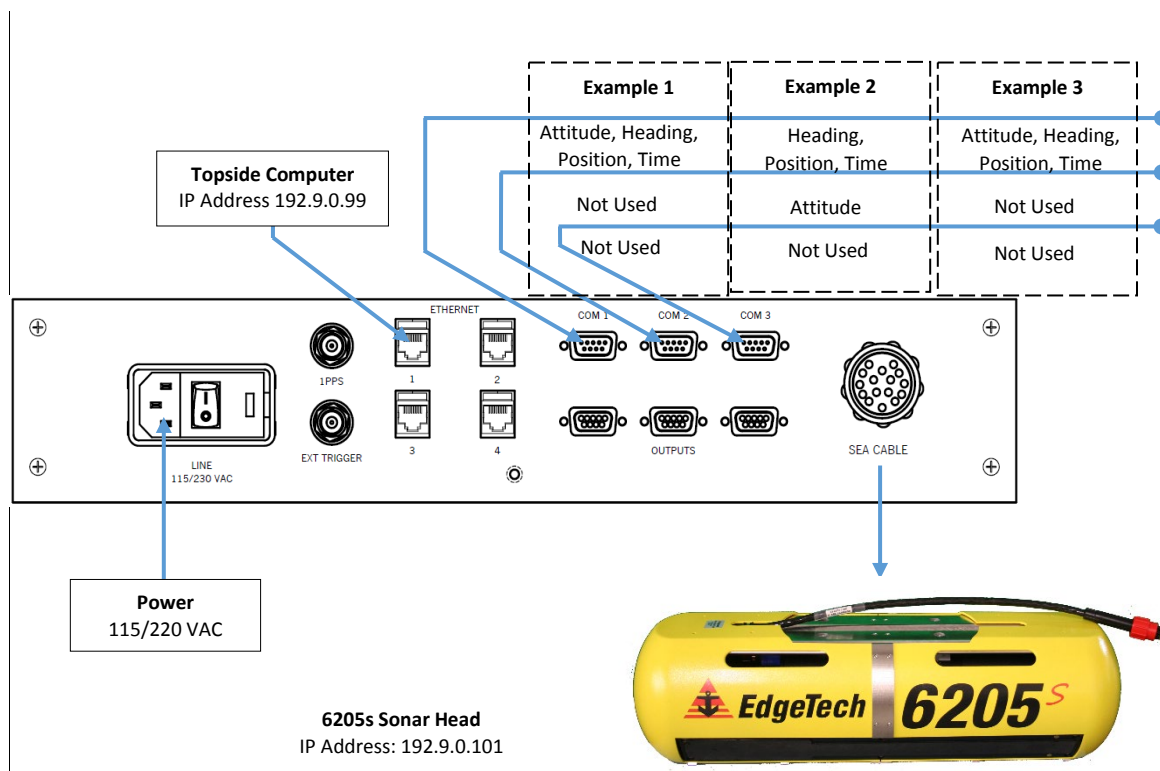

Figure 4-1: 6205s-R Rack Mount Topside Interface Connections

The 6205s-P Portable Topside Interface connections are similar and is presented in **FIGURE 3-10**.

In **FIGURE 5-1**, the 6205s Sonar Interface connects to Sonar Head via Deck Cable. Time, navigation, heading, roll, pitch, and heave data from supporting sensors via COM ports 1, 2, and/or 3, are inputted at Sonar Interface, passed through the Deck Cable, and logged by Sonar Processor in Sonar Head.

These data are transmitted (along with the raw side scan data) with a common timestamp up the Deck Cable to the 6205s Sonar Interface and are then passed to the Topside Computer through an Ethernet cable and via the 100Mbps link on Ethernet Port 1 (IP Address: 192.9.0.99).

The Topside Computer then processes these data using the DISCOVER BATHYMETRIC software to send amplitude, angle and range data to the 3rd party software for logging and post processing. This process is explained in further details in the following section. The 3rd party software and DISCOVER BATHYMETRIC processors may all run on the same computer.

4.2.3.1 Serial Port Configuration Examples

The example in [FIGURE 4-1](#) depicts a sensor interfacing to the 6205s Sonar Interface that provides time, navigation (latitude/longitude), heading, roll, pitch, and heave data over one serial connection—such as a NovaTel ProPak 6 or Applanix PosMV. As depicted in [FIGURE 4-1](#), the sensor is connected to COM1.

The second example shows the most common interfacing scenario, a GPS that provides navigation and heading data, accompanied by a motion sensor for attitude measurements.

The COM ports should be assigned as such:

- COM1 = MRU (Roll, Pitch, Heave)
- COM2 = GPS (Navigation and Heading)

These assignments may be interchanged between COM1 and COM2 because both ports have been configured for high speed and high accuracy. COM3 should not be used in this scenario.

The third and last example portrays a situation where the GPS does not provide heading data. In this case, three sensors are required: a GPS for navigation (latitude/longitude), a Gyro for heading, and a motion sensor for roll, pitch, and heave measurements.

Therefore, all three COM ports should be used and assigned as follows:

- COM1 = MRU (Roll, Pitch, Heave)
- COM2 = Gyro (Heading)
- COM3 = GPS (latitude/longitude/time)

The sensors allocated to COM1 and COM2 may be interchanged for the same reason stated in the second example. GPS data, or latitude and longitude data, must be allotted to COM3 because position can tolerate a 100ms latency, whereas attitude and heading are crucial to correcting wide swath of data.

NOTE: To configure the serial ports according to the examples given above, see [CONFIGURING COM PORTS](#).

4.2.4 Sonar Data Flow

The DISCOVER BATHYMETRIC software acquisition package provides a way to control, store, and display the bathymetry and side scan sonar data. DISCOVER BATHYMETRIC contains two processors: one to process the bathymetry solutions, called the Bathymetric Processor, and the second to process and display the dual frequency side scan data. To illustrate the data flow between DISCOVER, the Bathymetric Processor, and any Third-Party software, the block diagram in **FIGURE 4-2** is used.

NOTE: The 6205s Sonar Interface Box flow chart can be used in either the 6205s-R Rack Mount Interface Box or 6205s-P Portable Interface Box.

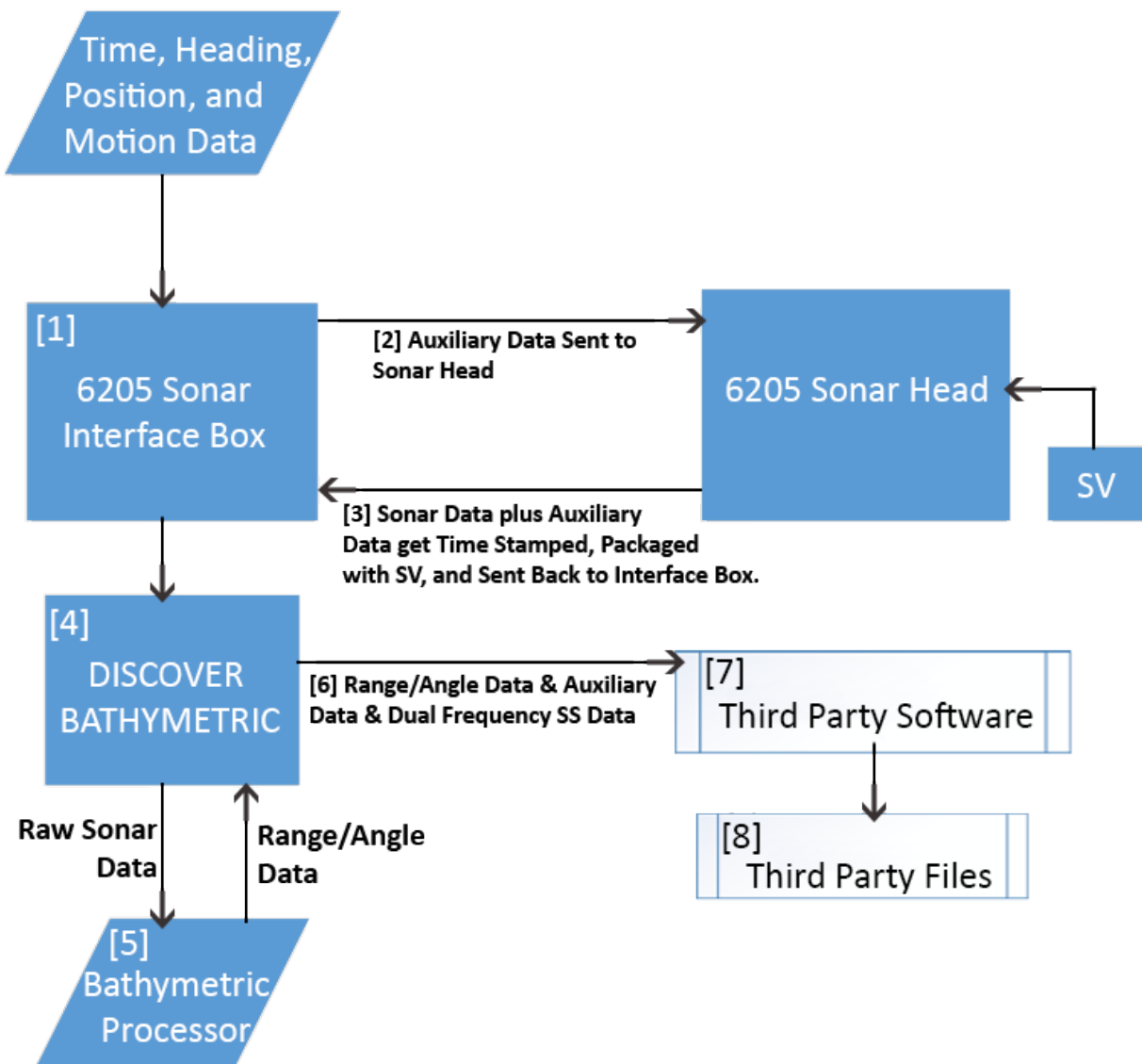

Figure 4-2: Sonar Data Flow

The flow chart in **FIGURE 4-2** demonstrates the following:

1. The auxiliary sensors provide time, heading, position (latitude/longitude), and motion (roll, pitch, and heave) data to the 6205s Sonar Interface Box via the provided RS-232 serial ports or UDP connections over the ethernet link.
2. These auxiliary data are then relayed to the 6205s Sonar Head via the Deck Cable.
3. Here, the auxiliary data are combined with the raw sonar data and instantaneous sound velocity (SV) measurements, where they are time stamped with a common value, and then sent back to the 6205s Sonar Interface.
4. DISCOVER BATHYMETRIC takes in the raw sonar data and sends it to the Bathymetric Processor.
5. The Bathymetric Processor processes the raw sonar data to produce uncorrected range and angle data, and then transmits this back to DISCOVER BATHYMETRIC, where it is packaged with the auxiliary and dual frequency side scan data. At this point, each ping is represented by a complete data package containing all sonar and auxiliary data.

NOTE: Once the data is passed back to DISCOVER BATHYMETRIC these data are shown on the provided graphical displays to illustrate the bathymetry and simultaneous dual frequency side scan data in real time. These data may also be recorded as a *.JSF file if the user desires.

6. This complete data package (range/angle, dual frequency side scan, and all auxiliary data) is sent to the Third-Party software.
7. The Third-Party software then logs these complete data packets to their native format. The Third-Party software also provides graphical displays to show the bathymetry, dual frequency side scan, and auxiliary data.
8. Finally, these three-dimensional Third-Party data files contain every piece of information to post process the data and generate hydrographic final products.

4.3 Topside Provided Isolation

The two most common sources of noise are Power Supplies and poor grounding on survey vessels. To protect against the noise fluctuations on the ground line of the subsea electronics, every Topside is shipped with EdgeTech's proprietary Signal Conditioning and Isolation Board. This board isolates the sensitive subsea electronics from potentially noisy grounds provided by the trigger and serial port inputs. Noise can often be identified as repeating patterns at the edge of the usable range of data within DISCOVER's Waterfall Display.

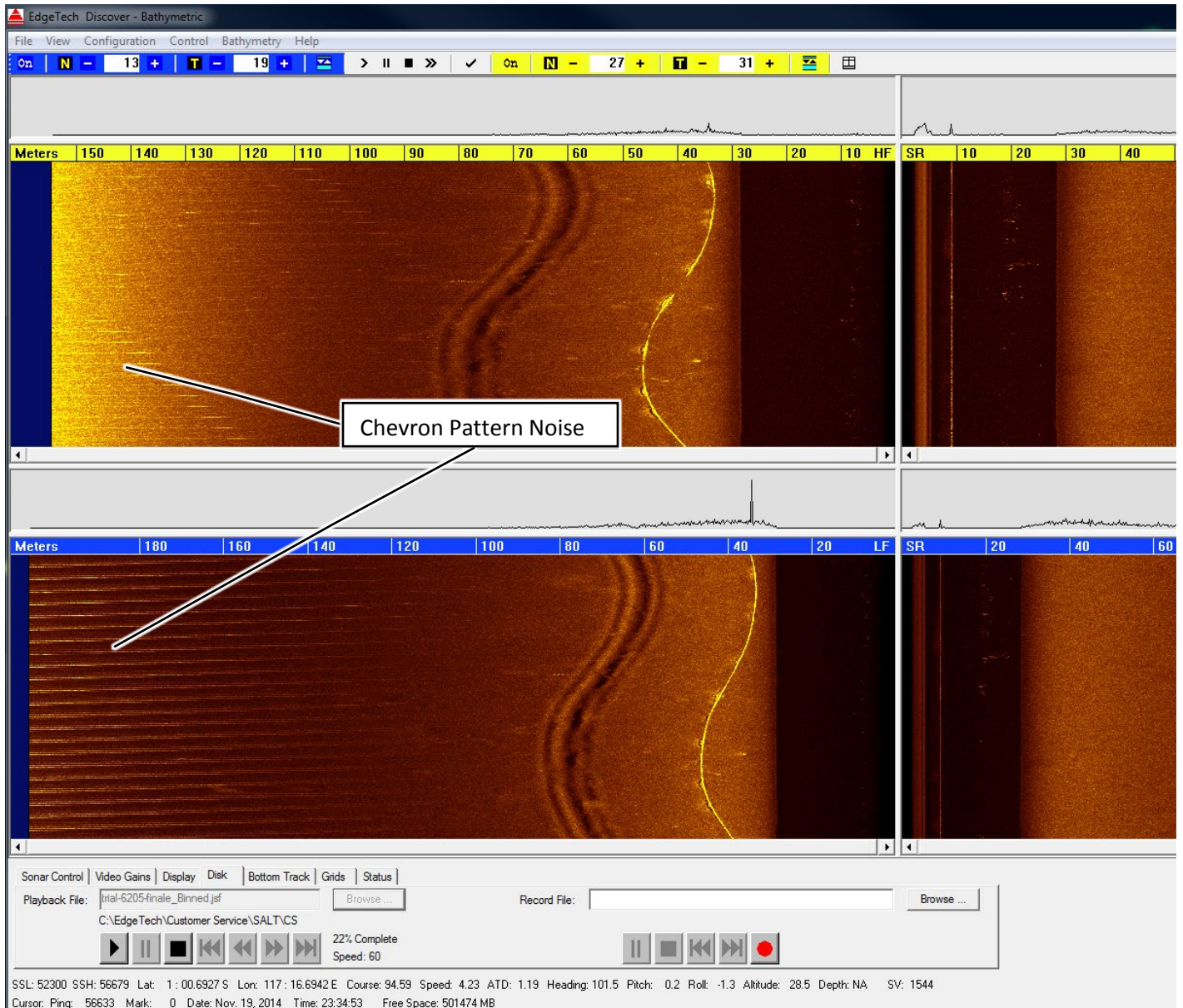

Figure 4-3: Chevron Pattern Noise in a Cropped Portion of Discover Bathymetric

SECTION 5: INSTALLATION

This section provides an overview for unpacking, inspecting, installing, and caring for the EdgeTech 6205s Swath Bathymetry and Dual Frequency Side Scan Sonar System.

5.1 Unpacking and Inspecting

The Sonar Head is shipped in a heavy duty and reusable transport case. The Interface Box with cables, optional Laptop, and USB are shipped in a cardboard box with appropriate packing material. All documentation, including manuals, is provided in electronic form on the USB.

Before unpacking the System's components, inspect the shipping containers for damage. If any damage is found, report it to the carrier and to EdgeTech immediately. If the shipping containers appear damage free, carefully unpack the components and inspect them.

Check the packing list and verify all the items on the list are included. If any damage is found after unpacking the components, immediately report it to the carrier and to EdgeTech. If any items are missing, contact **EDGE TECH CUSTOMER SERVICE**. Do not install or operate any equipment that appears damaged.

Although the items shipped may vary, depending on the customer's requirements, the standard components for the 6205s Swath Bathymetry and Dual Frequency Side Scan Sonar system are listed in **SECTION 1: OVERVIEW**.

5.2 Sonar Head Installation

Installing the 6205s System on the survey vessel is the customer's responsibility, but it is important to keep the following considerations in mind.

1. The Sonar Head can be mounted on the side of a vessel, but it is recommended to secure the 6205s to the bow of the boat.
2. If the customer wishes to mount the sonar off the side of their vessel, care must be taken to ensure keel clearance.

5.2.1 Over-the-Bow Deployment

The first, and recommended option, is to mount the 6205s Sonar Head to the bow of the survey vessel. An example of an over-the-bow deployment is depicted in the photographs in **FIGURE 5-1**. If help is needed with this type of installation, do not hesitate to contact **EDGETECH CUSTOMER SERVICE**.



Figure 5-1: 6205s Deployment, Option 1 – Over-the-Bow

5.2.2 Over-the-Side Deployment

An alternative to the bow mount is to secure the 6205s Sonar Head over the side of the survey vessel via a pole. An example of an over-the-side deployment is illustrated in the images in **FIGURE 5-2**. If help is needed with this type of installation, contact **EDGE TECH CUSTOMER SERVICE**.



Figure 5-2: 6205s Deployment, Option 2 – Over-the-Side

5.3 Positioning the Topside Interface Box

The Topside Interface Box can be set up several ways, depending on the model purchased. The 6205s-R 19-in Rack Mount version should be located and set up in a dry, sheltered area on the survey vessel that is protected from weather and water spray.

The 6205s-P portable design is a bit more versatile since it is watertight when closed (but cannot ever be submerged) and can be set up anywhere on the survey vessel that is most convenient. Care should be taken however, to keep the ends of the breakout cables dry.

Avoid areas of direct sunlight, especially in tropical environments, as heat build-up can occur and viewing status indicators can become difficult. Furthermore, the location should enable direct communications with the deck crew that is operating the survey vessel, Sonar Head, and other supporting sensors.

5.4 Topside Connections

After the Sonar Head has been installed, and the Topside Interface Box correctly placed on the survey vessel, the supporting sensors can now be connected. To connect the supporting sensors, Sonar Head, and Topside Interface Box:

1. Setup the MRU as described in the MRU's user manual.
2. Position and secure the MRU to the vessel's center of motion. If the MRU cannot be mounted in this location, then try to mount it as close as possible to the center of motion.
3. Setup the GPS as described in the GPS's user manual.
4. Position and secure the GPS Antennas so that they have a clear view of the sky. Also ensure that the GPS receiver is secured in a dry, sheltered area on the survey vessel that is protected from weather and water spray.
5. Ensure the sonar head is properly installed on the pole mount (whether at bow or vessel side).
6. Measure relative location of the MRU to the vessel's center of motion. If the MRU was mounted exactly at the vessel's center of motion, these measurements would be recorded as (0,0,0).
7. Measure the location of the GPS relative to the vessel's center of motion. Typically, the primary antenna is used as the source of position. In this case, use the location of the primary antenna to measure the installation offset for the GPS.

NOTE: These measurements are important and will be used later as installation offsets in the Third-Party software. Make sure to measure and note the exact location of the sensors to the vessel's center of motion. Also, remember the Z dimension is referenced to the water line.

8. Measure the location of the sonar head's acoustic center relative to the vessel's center of motion. The location of the acoustic center, as shown in [FIGURE 2-5](#) and [FIGURE 2-6](#).
9. Provide power to the 6205s Interface Box via the provided power cable.
10. Connect the Sonar Head to the 6205s Topside Interface box via the Subconn 16 pin connector.

11. Connect the MRU to COM1 and the Dual Head GPS to COM2 (or vice versa).
 - a. A MRU is used to measure the pitch, roll, and heave of the survey vessel.
 - b. A dual head GPS is used to gather heading and position (latitude/longitude) data.

NOTES: If the GPS does not supply heading (i.e. single head only), then a Gyro (or other source of heading) must be used. In the case where another sensor is needed to provide heading, the sensors should be connected as COM1 – MRU, COM2 – Heading, COM 3 – GPS. The low latency ports (COM1 and COM2) must be designated to the low latency sensor information (i.e., attitude and heading).

Refer to sub-section **3.2.2** for more information on connecting the COM Ports. Use **CONFIGURING COM PORTS** to configure the COM ports for the individual sensors.

12. Connect the 6205s Interface box to the topside computer using an Ethernet cable.
13. Turn the PC on and launch DISCOVER BATHYMETRIC Software.
14. If desired, launch any one of the supported Third-Party software packages setup the 6205s drivers, and input the installation offsets measured in steps **6** through **8**.

At this point, all equipment and software are ready for surveying.

See **SECTION 5: PRINCIPLES OF OPERATION** for use of the system.

5.5 Field Exchangeable Frequency Operations

The Field Swappable functionality is only possible with 230 / 550 kHz Side Scan systems.

In order to switch between different bathymetry frequencies, the 6205s Arrays must be exchanged with the corresponding Bathymetry Array. For instance, if the Sonar Head is currently configured as a 230 kHz/550 kHz Side Scan with 230 kHz Bathymetry and the user wants to exchange the Bathymetry frequency to the 550 kHz channel, then the following procedure should be followed.

Tools

- 1/16-inch Allen Wrench
- 3/16-inch Allen Wrench

1. Place the 6205s on a stable and level platform, such as a workbench or boat deck.



Figure 5-3: Unit on Stable Platform

2. Removing the [8] cap screws using a $\frac{1}{16}$ " Allen key, on the right and left sides of the housing.

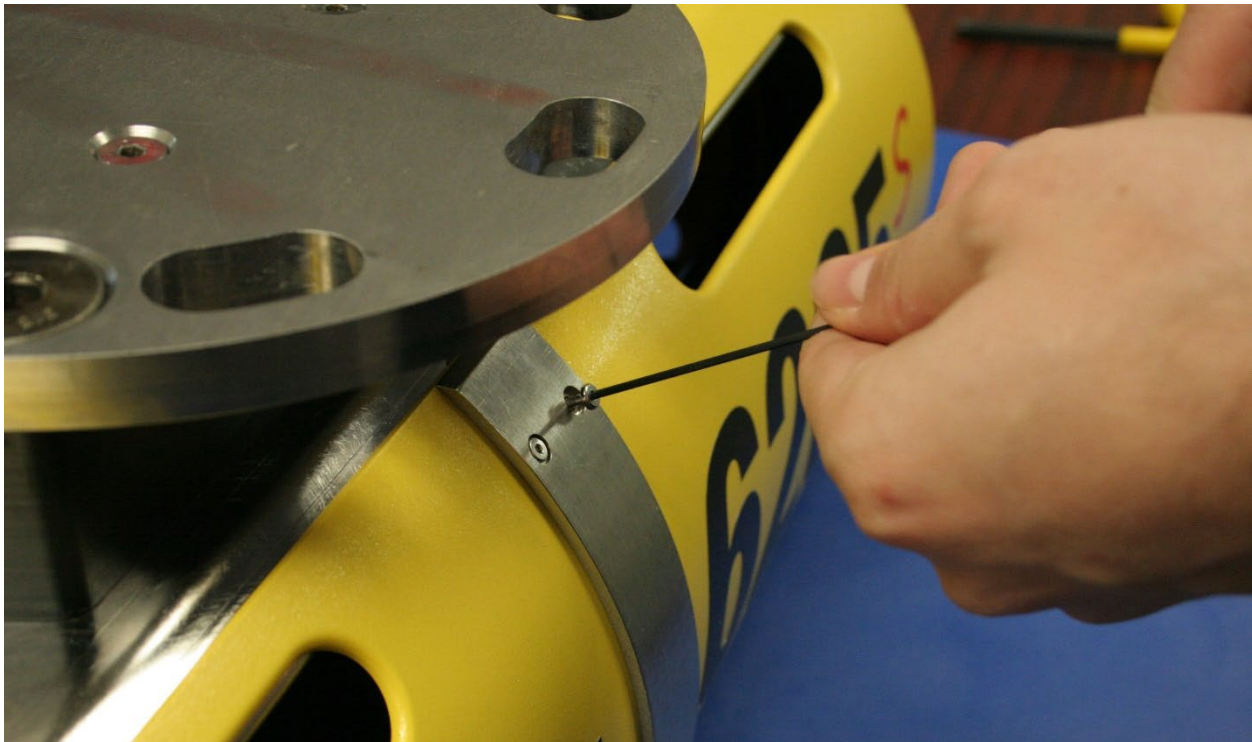

Figure 5-4: Removing the Cap Screws

3. Flip the 6205s over, so the bottom of the unit is upright to expose the remaining brackets.



Figure 5-5: Top Housing and Deck Cable Removed

4. Remove the [4] screws in the widest, center bracket.
5. Then, remove the [4] remaining screws in the [2] other brackets.

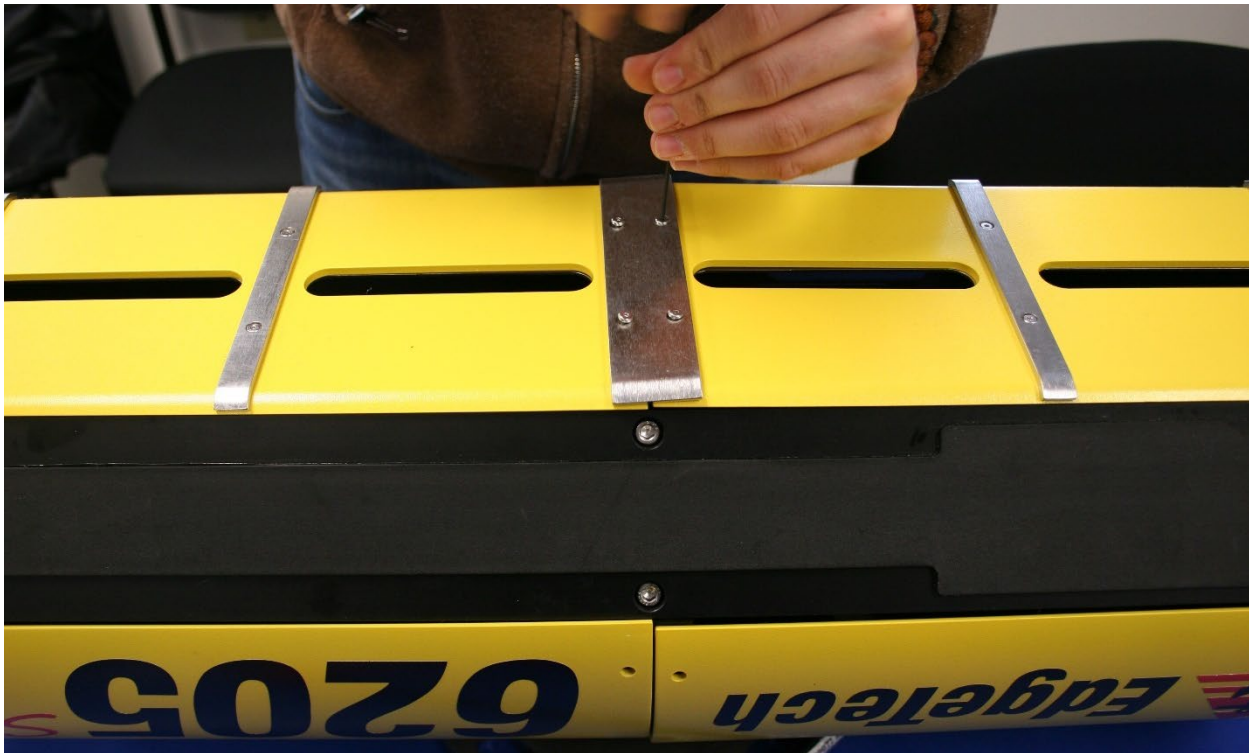

Figure 5-6: Remove the Center Bracket

NOTE: You DO have to remove the shell which the black pigtail come from. You DO NOT have to remove the front shell.

6. Slide the shell off the Housing.

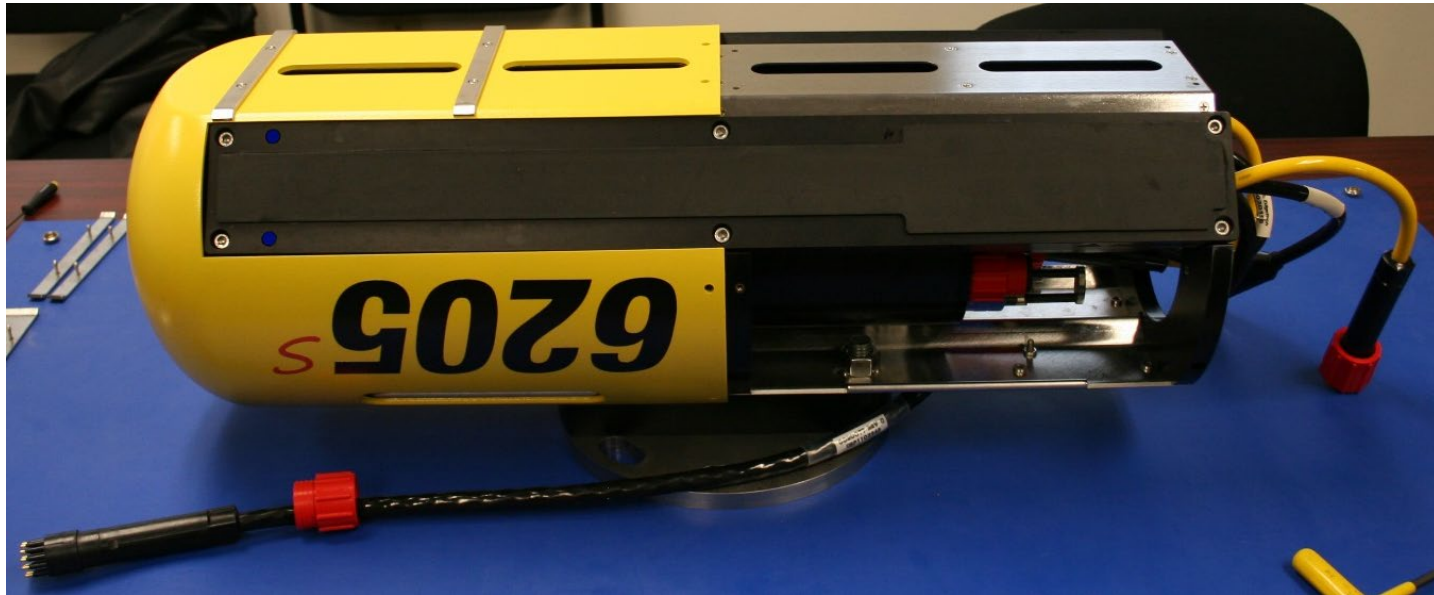

Figure 5-7: Remove the Portion of the Shell 'EdgeTech' and the Logo

7. Unplug the Bathymetry and Side Scan Sonar Cables on the Transducer you're replacing.

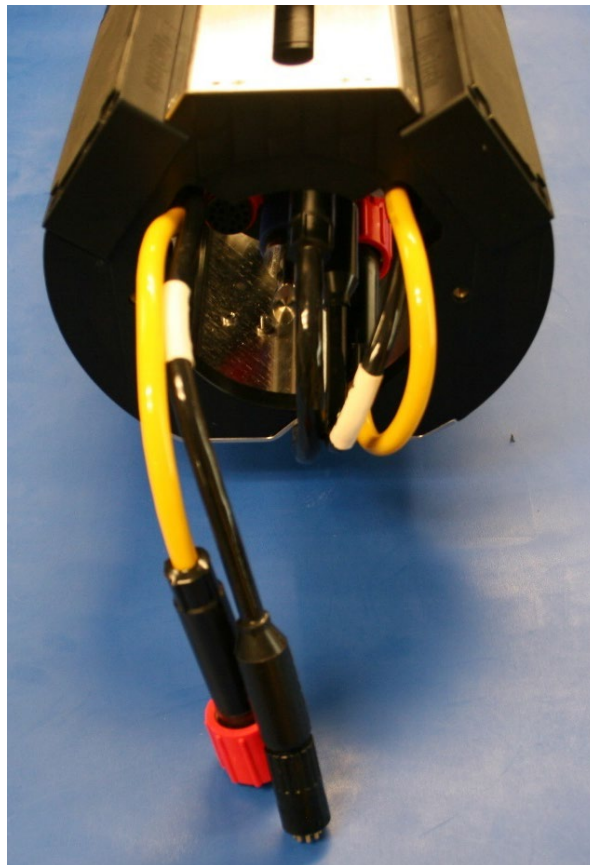

Figure 5-8: The Disconnected Bathymetry and Side Scan Sonar Cables

8. Remove all six $\frac{1}{4}$ " – 20 x 1.5" cap screws using the same $\frac{3}{16}$ " Allen key.



Figure 5-9: Remove the [6] Cap Screws



Figure 5-10: All Cap Screws Removed

9. To remove the Transducer, slide it away from the Housing and pull it straight out of the Frame. Take care not to damage the Side Scan and Bathymetry Cables out of the Frame.

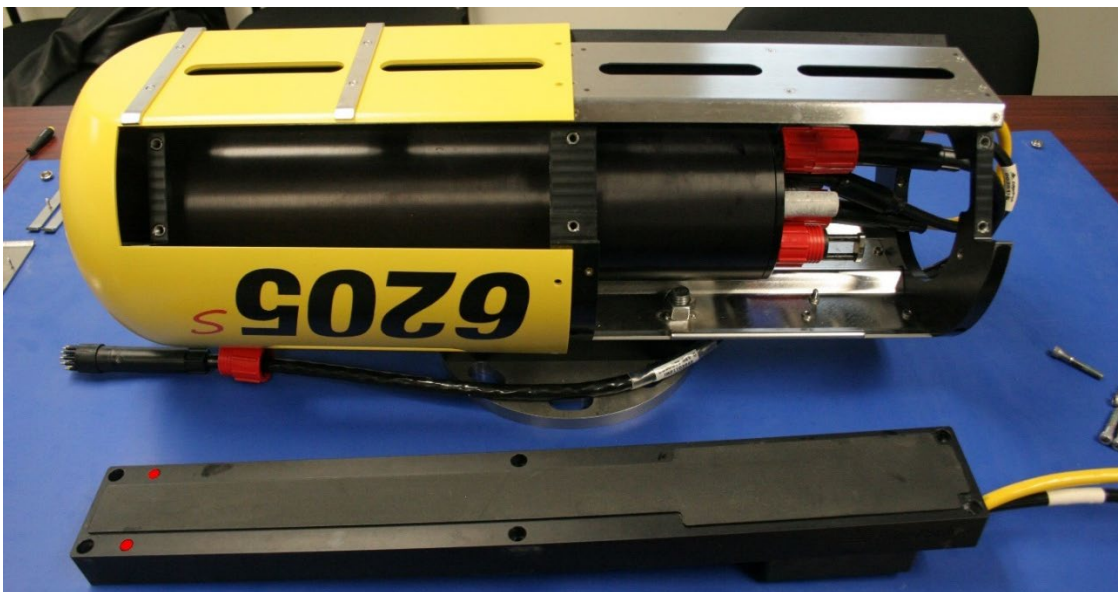

Figure 5-11: Remove the Existing Transducer

10. To mount the new Transducer, insert the Side Scan and Bathymetry Cables into the housing and through the Frame.

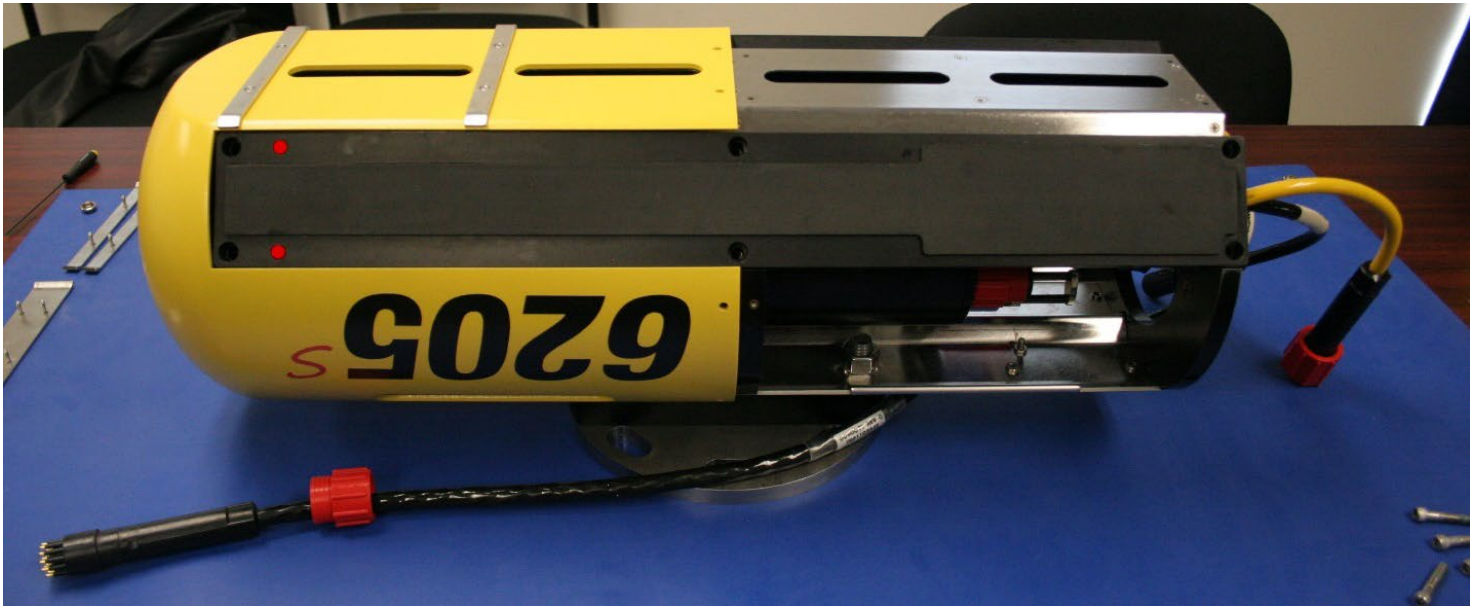

Figure 5-12: Mount the New Transducer

11. Place the Transducer onto the Frame and align the screw holes. To keep the Transducer in place, insert two screws on the top and bottom of opposing corners.
12. Repeat the same steps for the opposite Transducer.

CAUTION! Each array is labeled according to which side it corresponds to so ensure the port array is installed on the port side and the starboard array is installed on the starboard side. The sonar processor contains calibration data that is specific to each array and these must be installed correctly for calibration to be successful.

13. Complete the Transducer Installation by completing the steps above in reverse.

SECTION 6: CONNECT TO SONAR

This section describes how to connect to the sonar, ensure all supporting data is present within the system for proper operation, and correctly time sync the 6205s data. It also briefly describes the EdgeTech DISCOVER BATHYMETRIC software. For more information, refer to the DISCOVER BATHYMETRIC Software User Manual (0014878).

6.1 Connecting to Sonar via Remote Desktop

The user should only need to connect to the Remote Desktop Connection (Sonar.exe) and check to see the status of the supporting data if a device is not connected properly. If this is the case, DISCOVER BATHYMETRIC will display its diagnostic window and show which serial port is causing the error. It is not recommended to connect to the sonar without EdgeTech support, except for the Instructions Below.

There are two ways to connect to the 6205s Sonar depending on which interface box is connected:

1. **6205s-R**
2. **6205s-P**

6.1.1 Connecting with the 6205s-R

If using a customer-supplied computer with the 6205s-R (Rack Mount) Interface Box:

1. Navigate to the **Remote Desktop**. 'Start' button > All Programs > Accessories > Remote Desktop Connection. Alternatively, click 'Start' button, type **mstsc** in Search, and hit <Enter>. The following window will appear:

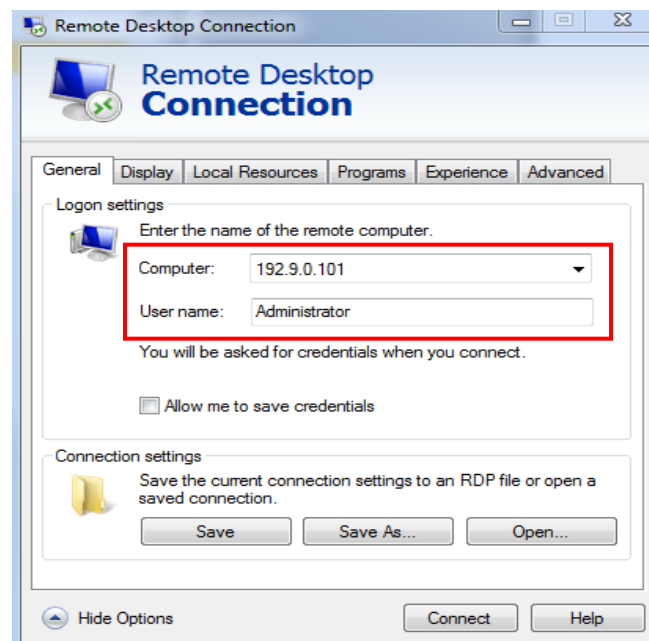

Figure 6-1: Manual Remote Desktop Credentials for Customer Supplied Computer

2. Connect to the 6205s Sonar using an IP address of **192.9.0.101** and User name of **Administrator**.
3. When prompted for a password, input **admin**. Once logged on, the following window will appear:



Figure 6-2: Sonar 192.9.0.101 Remote Desktop Connection Window

This window represents the main firmware running on the embedded CPU located in the bottle of the Sonar Head. Called *Sonar.exe*, this program is responsible for controlling the sonar's hardware and performs specific functions such as the signal processing and time synchronization of the acquired data.

6.1.2 Connecting with the 6205s-P

If using an EdgeTech supplied laptop with the 6205s-P (Portable Topside) Interface Box:

1. Launch the **Remote Desktop to Sonar** application on the desktop screen. If prompted for a password, input **admin**.

Once logged on, the Sonar Application will be displayed on the screen, as shown in **FIGURE 6-2**. This window represents the main firmware running on the embedded CPU located in the bottle of the Sonar Head. Called *Sonar.exe*, this program is responsible for controlling the sonar's hardware and performs specific functions, such as the signal processing and time synchronization of the acquired data.

6.2 Confirming Supporting Data is Present

To ensure Sonar Head's processor is communicating properly with the Topside, complete the following:

NOTE: This section assumes all auxiliary sensors have been connected to the 6205s Interface Box (whether this is the 6205s-R or 6205s-P) the Sonar Head is installed on survey vessel and is submerged in seawater.

1. On the Desktop, launch **Remote Desktop to Sonar**. The following window should appear:

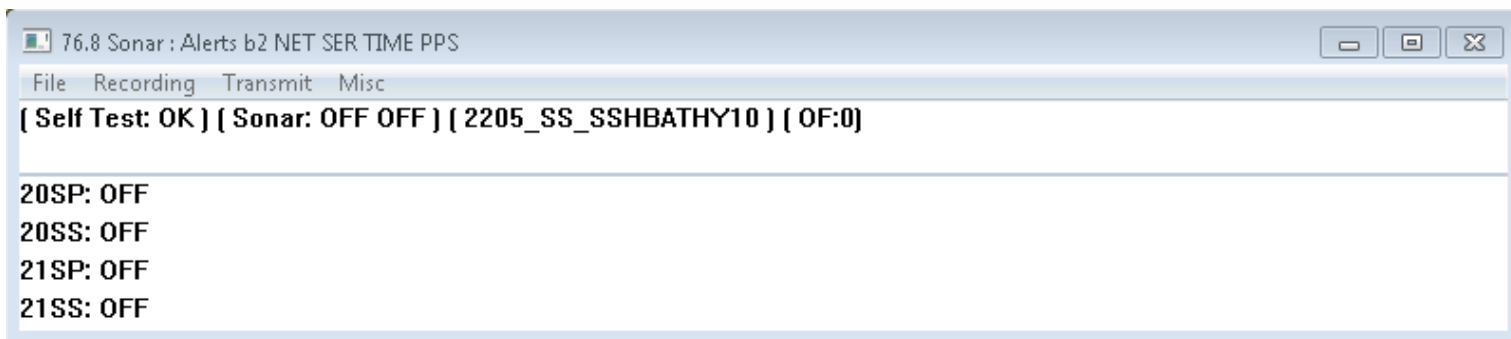

Figure 6-3: Sonar 192.9.0.101 Remote Desktop Connection Window

2. Click on Menu > Misc > Serial Port Information.
3. Check each COM port in the drop-down menu to ensure the correct baud rates are set and data is coming through for each device and in the correct format, as shown in **FIGURE 6-4**.
 - a. COM1 = MRU
 - b. COM2 = GPS
 - c. COM4 = Sound Velocity Sensor located in the Sonar Head's housing

NOTE: GPS and MRU are interchangeable on COM1 and COM2 as long as the appropriate baud rate is set in drop-down menu next to channel assignment in Serial Port Information Window, as shown in **Figure 6-4**, red arrow.

More information on how to configure the COM ports is presented in **CONFIGURING COM PORTS**.

If all systems are working properly, close this window and proceed to Step 4. If there is an issue with one of the ports, contact **EDGETECH CUSTOMER SERVICE**.

CAUTION!

Sound velocity is extremely important for the system to operate correctly. If sound velocity measurements are not present (i.e., port is reporting no data), use **SECTION 7: TROUBLESHOOTING** to go through the troubleshooting process.

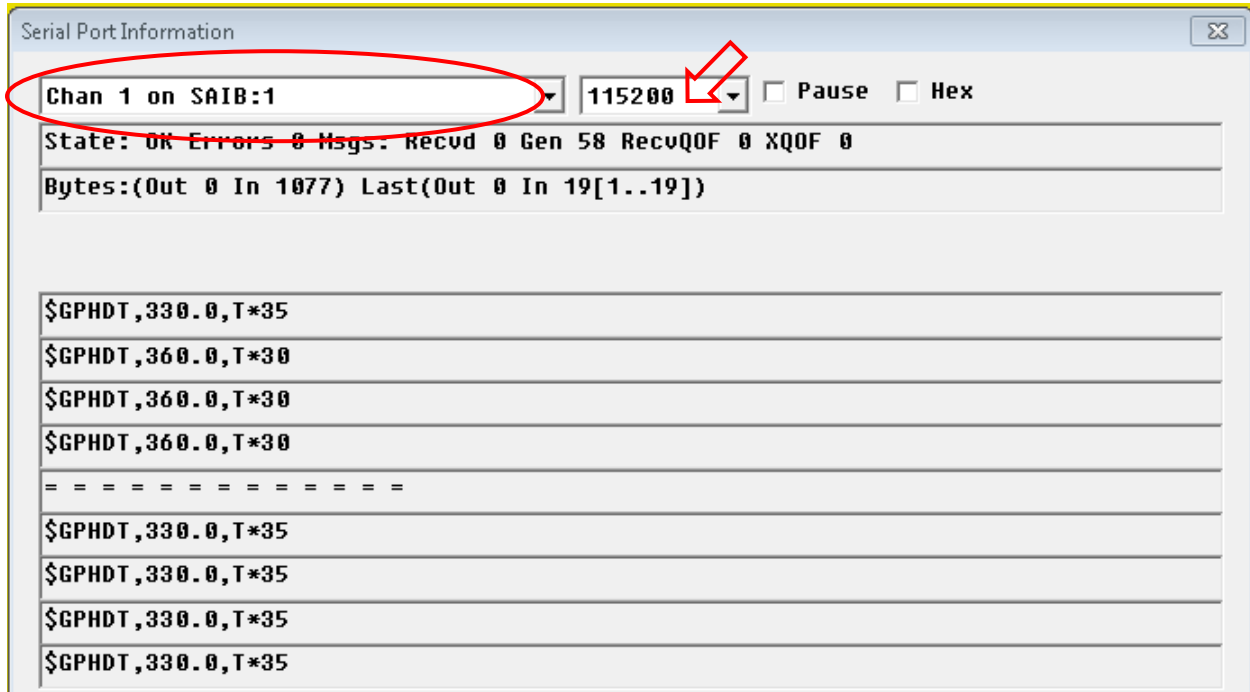

Figure 6-4: Serial Port Information Window

4. Click on Menu > **File** > **Show Status**. The System Status window will appear.
5. At the bottom of the window, click the **Config** bullet, then the drop-down menu item named **Config Item**.
6. Select **Serial** from the list.
7. Check to make sure all sensors' usage percentages are well below 80%, as shown in **FIGURE 7-5**. If they are not, increase the baud rates of the sensors until these percentages drop. Make sure to change the baud rate accordingly in **Sonar**.
8. When satisfied with the incoming data, press **OK** in the System Status window, and then close the **Sonar - 192.9.0.101 - Remote Desktop Connection** window.

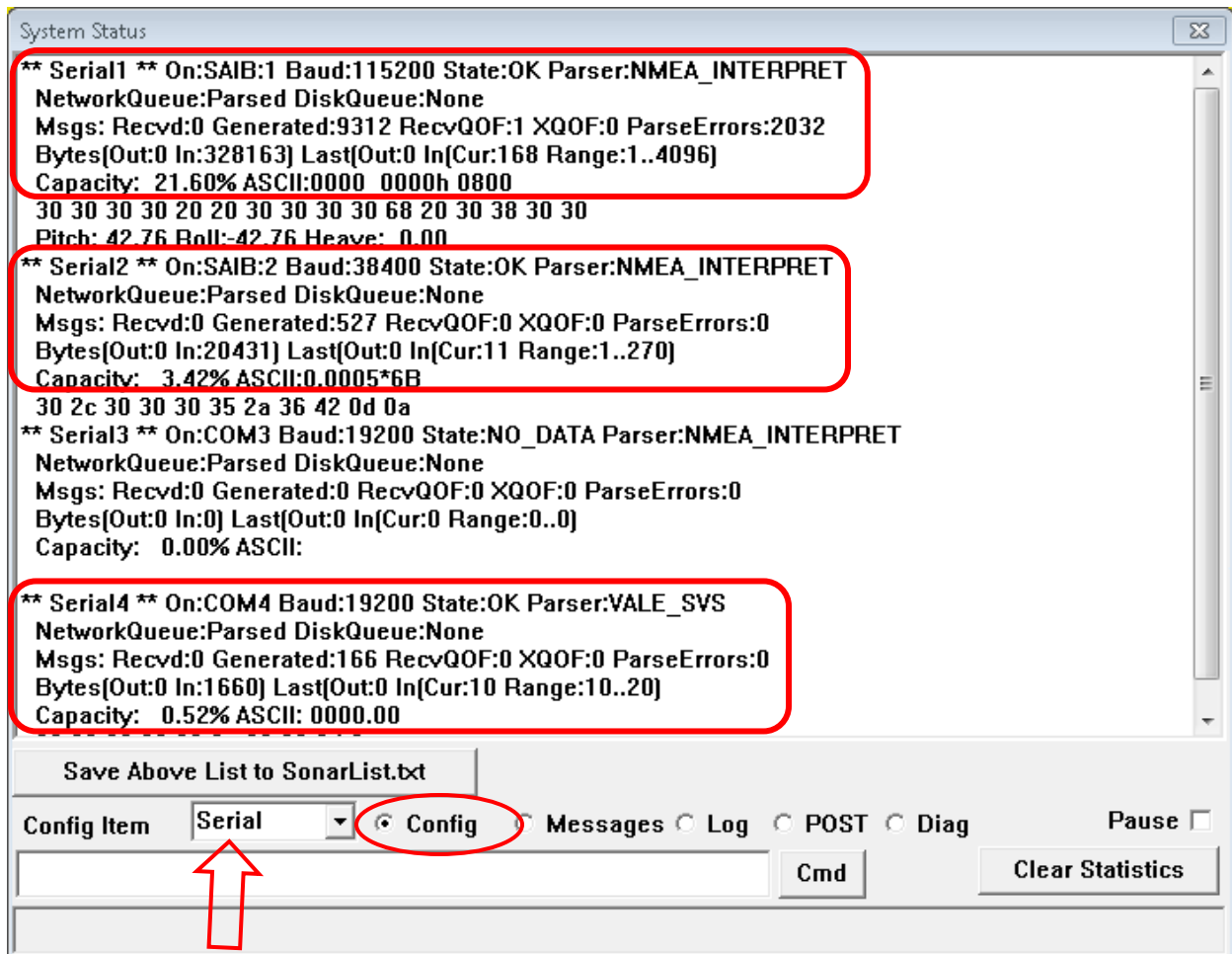

Figure 6-5: System Status Window

RTK Tide measurements can be incorporated to the 6205s System. Most Third-Party Software packages can set up a device driver to acquire these data. A 1PPS sync is needed in this case, as these measurements are typically manipulated offline.

SECTION 7: MAINTENANCE

The 6205s Sonar Head is not designed for long-term deployments, and it is not recommended to keep the system in water for more than two weeks at a time, especially in warm, salty waters.

After each mission, the system should be rinsed thoroughly with freshwater, making sure to rinse the SVS, which is mounted onto the Connector Endcap, and connectors at the back using the carry slots located on the sonar housing. Pay special attention to the SVS sitting in the bottom portion of the housing, and the connectors towards the back of the housing, rinsing them thoroughly using the rinse holes provided.

EdgeTech recommends regularly checking the array faces. Fouling and corrosion may degrade the measurements of the 6205s system and/or the Sound Velocity Sensor in the bottom of the Sonar Head. If fouling is observed, clean them using a wash cloth with mild soap and fresh water. The SVS, mounted onto the Connector Endcap, should be regularly inspected and cleaned, as well as calibrated once every two years.

The faces of the arrays should also be inspected after each deployment for organism growth or damage. If any residue is noticed, clean the array faces using a wash cloth with mild soap and water. If any damage is observed, contact [EDGE TECH CUSTOMER SERVICE](#) immediately.

CAUTION!

The 6205s Sonar Head's transducers should NEVER be turned on when out of water, because the unit will overheat, causing permanent failure. In limited circumstances, the 6205s can be turned on, without the Transducers, to retrieve data, however, this should never exceed 30 minutes. Additional time can be added with air conditioning, but even then, it should never exceed one hour.

SECTION 8: TROUBLESHOOTING

8.1 Troubleshooting the SV Sensor

In some cases, the sound velocity sensor may not boot properly. If this occurs, DISCOVER BATHYMETRIC will show a **Port 4: Error** on its **Diagnostic Window** indicating that no sound velocity measurements are being reported to the sonar head. An example of this error is shown in **FIGURE 9-1**.



Figure 8-1: No Sound Velocity on Port 4

If this error persists longer than 30 seconds, follow the procedure below to resolve the issue:

1. Place the Sonar Head in water deep enough to submerge the SV probe (the bottom half of the shell is submerged). This will submerge the sound velocity sensor as well.
2. On the Desktop, launch **Remote Desktop to Sonar**. The following window should appear:

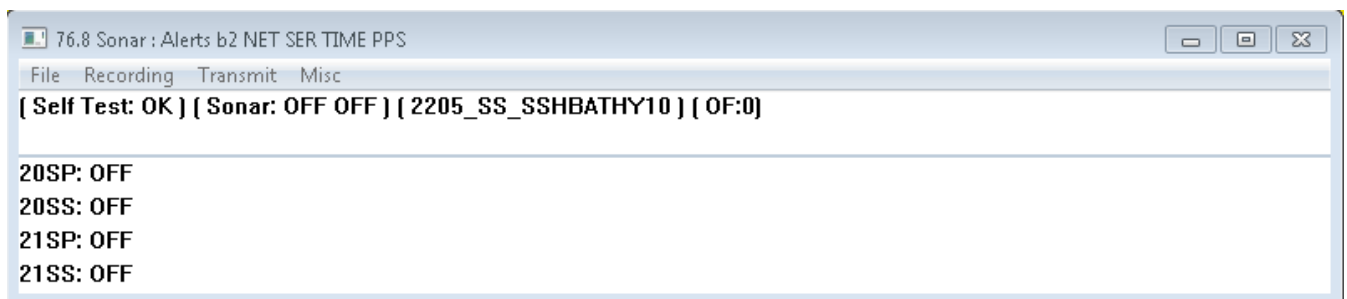

Figure 8-2: Sonar 192.9.0.101 Remote Desktop Connection Window

3. Click on Menu > Misc > Serial Port Information.
4. Check **Chan 4 on Com 4** from drop-down list to see if there is any data being reported by port.

5. If no data is present, cycle the power on the sonar head using the On/Off switch on the interface box. Allow the sonar to be off for at least 10 seconds before turning it back on.
6. Once the sonar is reconnected, go back into the **Remote Desktop** application and check **Chan 4 on COM 4** again as in step 4 above.
7. If data is reported by the port, then proceed to normal operation. If not, continue to step 8.
8. Close out of *Sonar.exe* by clicking on the 'X' in the top right corner, as shown in **FIGURE 8-3**, red arrow.

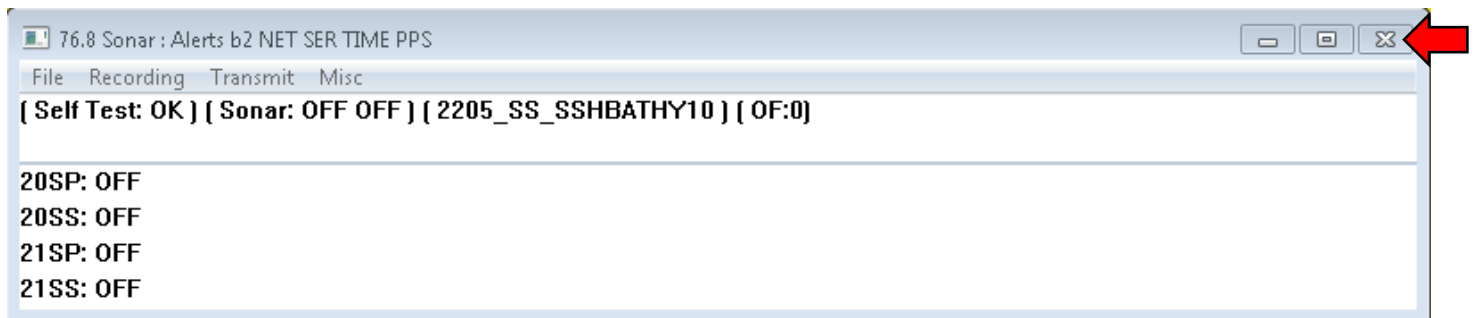

Figure 8-3: Closing the Sonar.exe Application

9. Double click the "EdgeTech Shortcut" and navigate to Utilities/Teraterm folder. Launch **ttermpro.exe**.
10. Select **Serial**, choose **COM4** from the drop-down menu, as shown in **FIGURE 8-4**, and click **OK**.

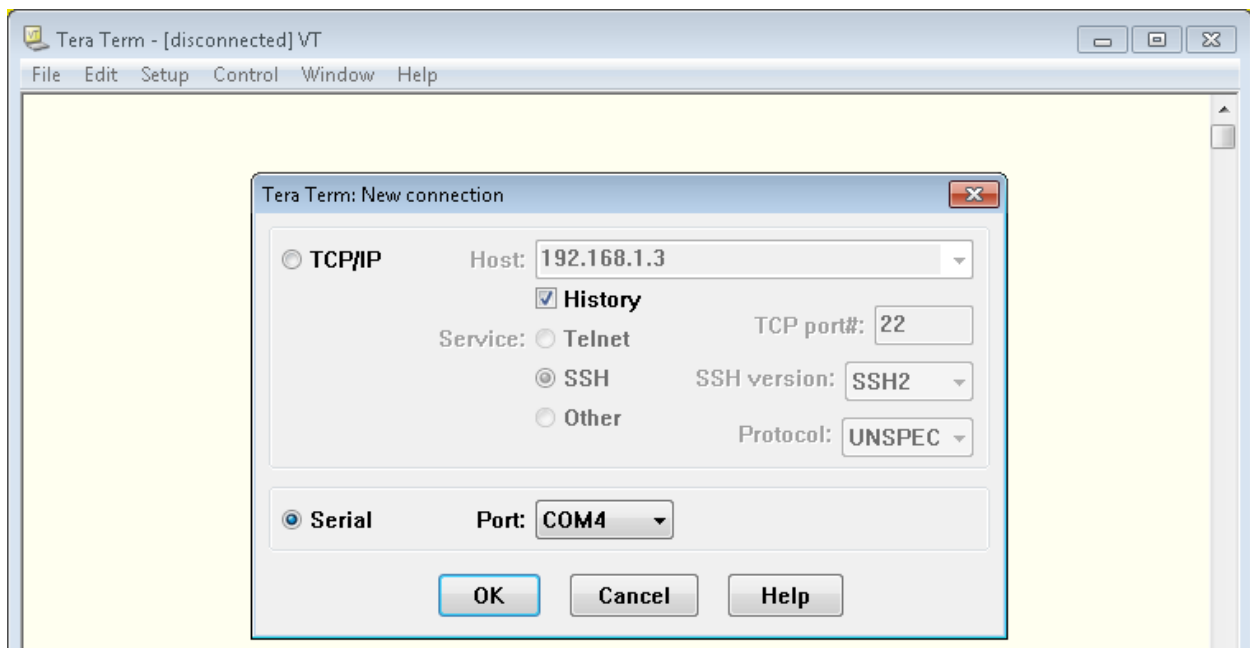

Figure 8-4: Connecting to COM4 using TeraTerm

11. Now, choose **Setup** from the top menu and then **Serial port**.
12. Configure the serial port options, as shown in **FIGURE 8-5**, and click **OK**.

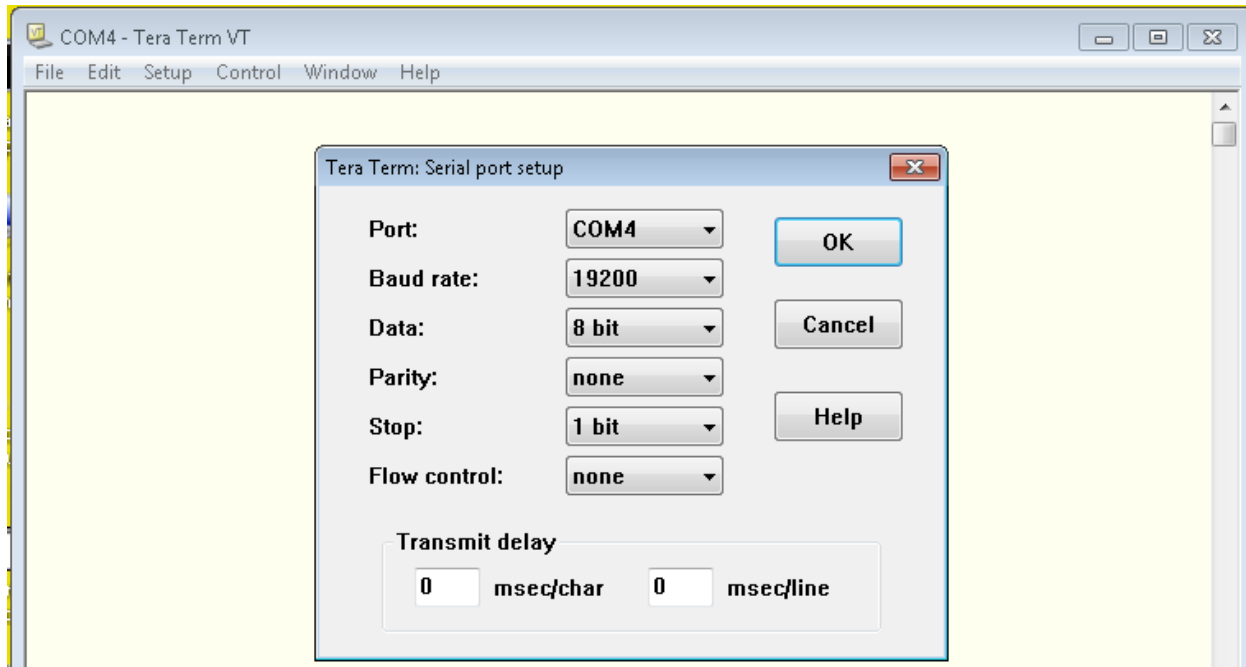

Figure 8-5: COM4 Port Settings

13. Input the following commands:

- Hit <Enter> to start communications to SV sensor.
- Type in "SET STARTUP NOHEADER" and <Enter>.
- Type in "SET STARTUP MONITOR" and <Enter>.
- Type in "SET SV FORMAT 42" and <Enter>.
- Type in "SET SV ZEROSUPPRESSION 5 seconds" and <Enter>.
- Type in "SET SVAVERAGE 4" and <Enter>.
- Type in "SET SAMPLE 1/S" and <Enter>.
- Type in "SET DETECT 06" and <Enter>.

14. Cycle the power on the Sonar Head using the On/Off switch on the interface box. Allow the sonar to be off for at least 10 seconds before turning it back on.
15. Reconnect to the sonar via the Remote Desktop and check COM4 using the Sonar application as before in steps 3 and 4 above. SV data should not be scrolling as in:

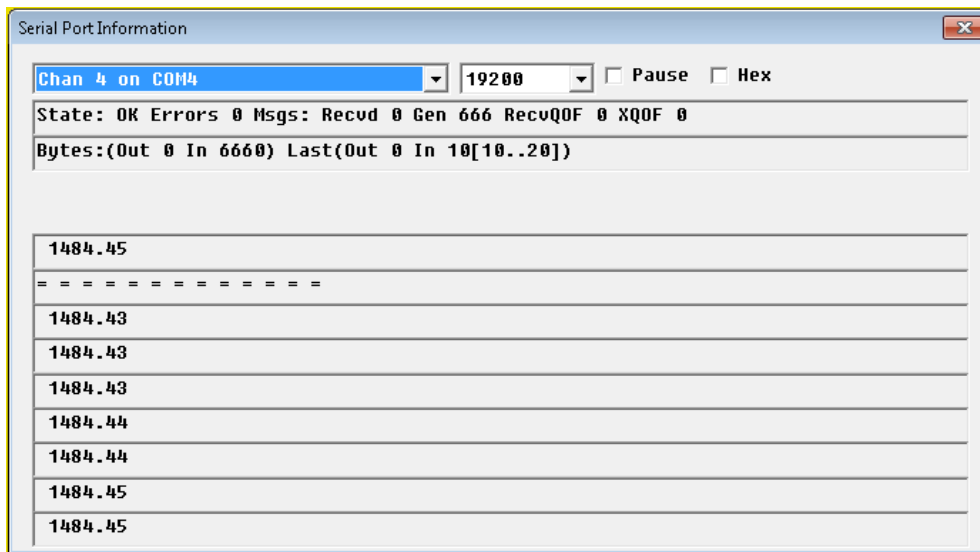

Figure 8-6: Scrolling SV Data in Sonar.exe

16. If SV data is still not present, contact [EDGETECH CUSTOMER SERVICE](#) with the noted information.

8.2 Configuring Auxiliary Sensors for Redundant Information

Redundant auxiliary information is defined here as multiple sources of the same class of auxiliary information (e.g. roll, pitch, heading) being inputted to the 6205s Interface box. Redundant auxiliary sensor information, especially heading, can cause a significant alignment problem in the 6205s data and must be avoided at all costs.

Sequential sonar data packets will be stuffed varying from source, causing inconsistency. In the event the auxiliary sensors cannot be reprogrammed to output select data messages the DISCOVER software should be configured so that only one specific source of information is used. There are two scenarios of redundant data: Two Sensors Supplying the Same Message String, and Two Sensors Supplying the Same Information but from Different Messages. Ensure to follow the correct procedure outlined below as it varies depending on the output strings available from the auxiliary sensors.

8.2.1 Two Different Sensors Supplying the Same Message

If two different sensors are outputting the same message (NMEA HDT, for example) and the sensors cannot be reprogrammed, then DISCOVER BATHYMETRIC Software has to be configured to accept the HDT information from one of the sensors only. To do so, use the procedure described below.

NOTE: The configuration described below only works if there are two sensors outputting the same specific message (like HDT). It does not, however, work for different messages that contain the same information (i.e. OCTANS and HDT). Refer to Scenario 7.3.2 in this case.

1. Open the Auxiliary Sensors control dialog box (**Configuration** menu > **Auxiliary Sensors**), as shown in **FIGURE 8-7** and **FIGURE 8-8**.

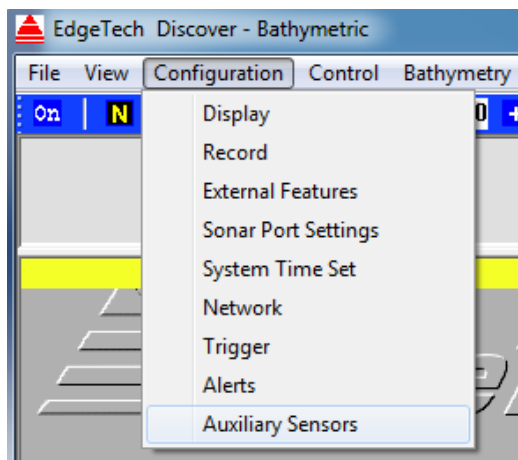

Figure 8-7: Configuration Menu

 The screenshot shows the 'Auxiliary Sensors' dialog box with a table of sensor configurations. The table has columns for sensor name, status, Total, Not Processed, and Average Rate (Hz). Several rows are highlighted with colored boxes: GGA, HDT, VTG, and GGK are highlighted in red, and HDT is highlighted in green.

		Total	Not Processed	Average Rate (Hz)
Pitch / Roll:	ON	1668	0	55.87
Pressure:	ON	35	35	1.11
Altitude:	ON	0	0	---
SV:	ON	35	0	1.11
NMEA:		1369	0	
GGA:	COM1	334	0	11.11
GLL:	OFF	0	0	---
RMA:	OFF	0	0	---
RMC:	OFF	0	0	---
HDG:	OFF	0	0	---
HDT:	COM2	0	334	11.11
DPT:	OFF	0	0	---
DBT:	OFF	0	0	---
VTG:	COM1	334	0	11.11
ETC:	OFF	0	0	---
GGK:	COM1	334	0	11.10
HYDRO:	OFF	0	0	---
PASHR:	OFF	0	0	---
HEAVEA:	OFF	0	0	---

Figure 8-8: Auxiliary Sensors

- Specify what serial port to use for each particular input message. In **FIGURE 8-8** COM1 is used to feed GGA, VTG, and GPK, as shown in **FIGURE 8-8**, red box, to the 6205s Sonar Head, while COM 2 feeds in HDT, as shown in **FIGURE 8-8**, green box.
- When satisfied with the serial port setup, click on the **X** at the top right of the dialog box.
- Monitor status bar at the very bottom of DISCOVER to ensure all supporting data is present, as shown in **FIGURE 8-8**, red box.

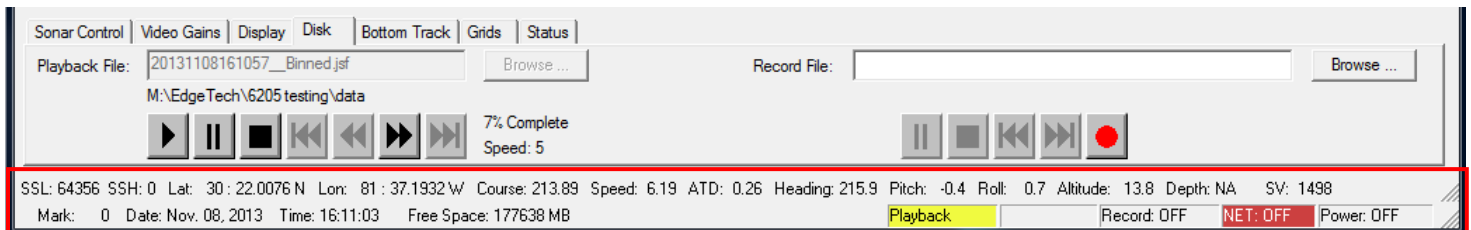

Figure 8-9: Sonar Control Tab

NOTE: For more information, refer to the DISCOVER BATHYMETRIC Software Manual (PN 0014878).

8.2.2 Two Sensors Output Same Information with Different Messages

Some motion sensors cannot turn off specific fields within their output strings. For example, a sensor that outputs an OCTANS message delivers roll, pitch, heading, and heave to the 6205s Sonar Head with no way for the particular sensor to turn off any of these specific fields. If a sensor like this is paired with another sensor that outputs the same information but in a different message format (i.e. NMEA HDT), then there is redundant information being supplied to the system. As stated before, this poses a problem and can lead to a significant alignment error in the 6205s data.

To correct this, the 6205s can be programmed to ignore specific fields within one particular message. Use the example above and state the second heading sensor is preferred. Proceed to the following steps:

- Log in to Remote Desktop as outlined in sub-section 5.1.
- Double click on the folder labeled “Shortcut to EdgeTech Folder”.
- Navigate to the D:/EdgeTech/SSSSonarBathy/Sonar and open the **SonarSerial.ini** file.

WARNING

Be careful in manipulating this file and only change what is stated in these directions. Changing any other field may cause sonar malfunction.

- Find the serial port outputting the redundant message and under **Parser** field add the words **ParserParameters=DISABLEHEADING** For example, if COM 1 on interface box is used to input an OCTANS message at a baud rate of 38400, then SonarSerial.ini should be manipulated to reflect, as shown in **FIGURE 8-10**.

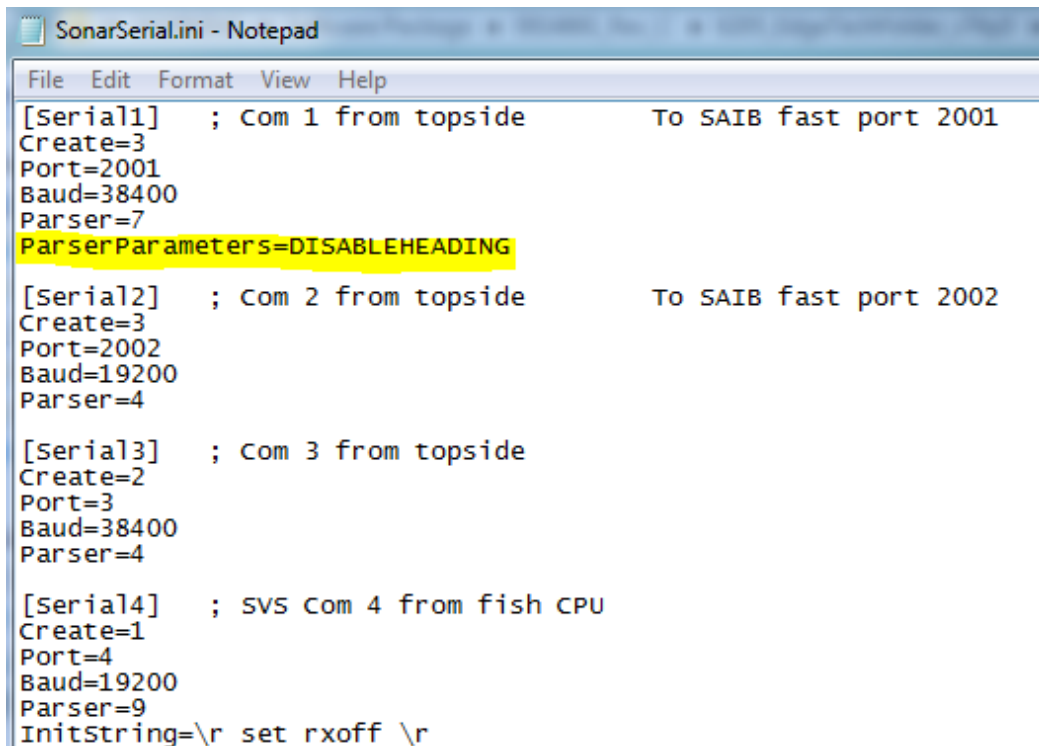

```

SonarSerial.ini - Notepad
File Edit Format View Help
[Serial1] ; Com 1 from topside To SAIB fast port 2001
Create=3
Port=2001
Baud=38400
Parser=7
ParserParameters=DISABLEHEADING
[Serial2] ; Com 2 from topside To SAIB fast port 2002
Create=3
Port=2002
Baud=19200
Parser=4
[Serial3] ; Com 3 from topside
Create=2
Port=3
Baud=38400
Parser=4
[Serial4] ; SVS Com 4 from fish CPU
Create=1
Port=4
Baud=19200
Parser=9
InitString=\r set rxoff \r

```

Figure 8-10: SonarSerial.ini

NOTE: This new keyword disables heading message from the OCTANS message. The same can be done with an EM1000 binary format message. Heading and heave are currently the only fields that can be enabled/disabled in the SonarSerial.ini file.

To disable heave: ParserParameters=DISABLEHEAVE

- Save the file and exit.
- Power cycle the 6205s Sonar Head, allowing at least 15 seconds between switching off and on.

APPENDIX A: CONFIGURING COM PORTS

There are three available COM ports on the Interface Box to provide the necessary information to the 6205s. This information includes position (latitude/longitude), heading, attitude (roll, pitch, and heave), and time. This appendix explains how to configure the three COM ports depending on what type of sensors are used.

NOTE: Most of the COM port configuration can and should be completed via the Discover Bathymetric Software.

A.1 One Sensor

One sensor, such as the Applanix PosMV, may be used to supply position (latitude/longitude), heading, attitude, and a time source. For this type of configuration, only COM1 will be utilized.

To configure the COM ports for one sensor:

1. Turn on Topside PC and connect the 6205s via the deck cable to the 6205s Topside Interface Box.
2. Turn on the 6205s Sonar Head and run the Remote Desktop Application, named Sonar. The main screen, as shown in **FIGURE A-1** should appear.

Here, the user will see the Sonar Application running (designated by the blue arrow). This is the firmware that controls the system.

3. Click on the 'X' at the top right to close the firmware.
4. Double click on Shortcut to EdgeTech icon, as shown in **FIGURE A-2**, red arrow and open SSSonarBathy folder, then Sonar folder.
5. Look for the SonarSerial.ini file, as shown in **FIGURE A-3**, and open it using WordPad or Notepad, as shown in **FIGURE A-4**.
6. Under [Serial2] and [Serial3] set Create = 0, select File > Save, and close the file.

CAUTION!

Do not alter the file in any way other than what has been specified.

This will deactivate COM ports 2 and 3. By deactivating these ports, Sonar will report to DISCOVER that only one sensor is to be used on COM1 to parse the necessary sensor information. Therefore, DISCOVER will not display any errors if a sensor is not connected to COM2 or COM3.

If steps 3 through 6 were not carried out, then these errors would be reported in the Diagnostic window, as shown in **FIGURE A-5**.

7. Close the SonarSerial.ini file and reboot the Sonar Firmware by double clicking on the Sonar icon in the main Sonar Remote Desktop Screen, as shown in **FIGURE A-6**, designated by green arrow.

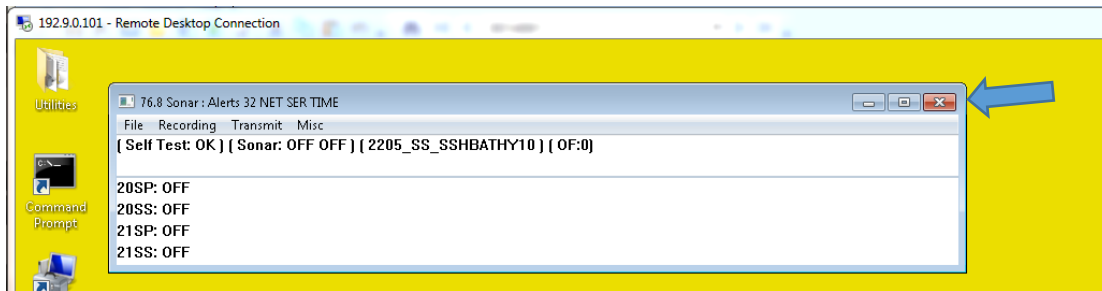

Figure A-1: Sonar Remote Desktop Application, Main Screen

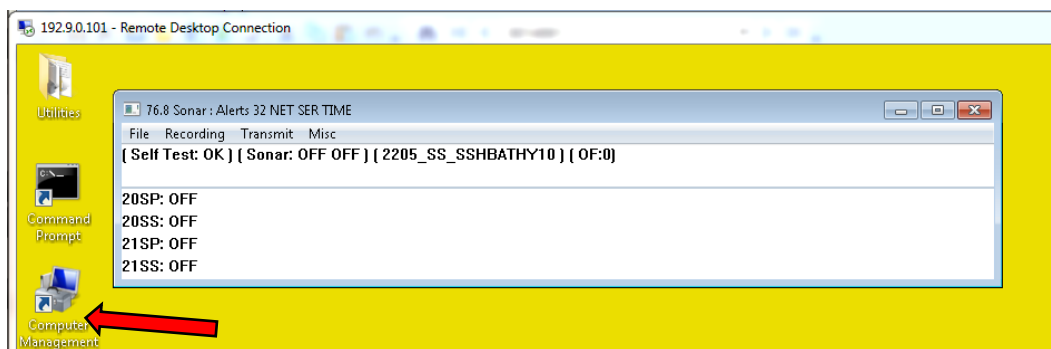

Figure A-2: Sonar Remote Desktop, Shortcut to EdgeTech Folder

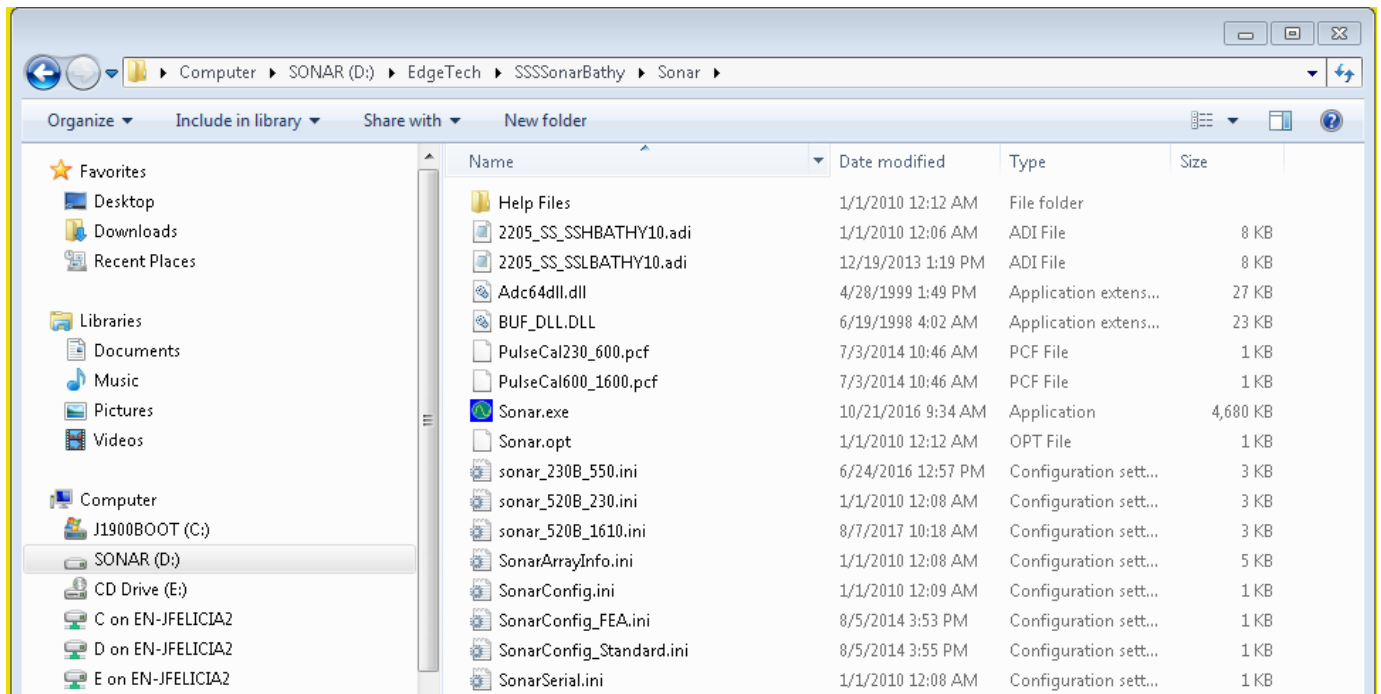

Figure A-3: Finding the SonarSerial.ini File

```

SonarSerial.ini - Notepad
File Edit Format View Help
[[Serial1]          ; SAIBU Fast Port 2001 (Com 1 Topside)
Create=3
Port=2001
Baud=19200
Parser=4
;ParserParameters=HEAVESCALE -1

[Serial2]          ; SAIBU Fast Port 2002 (Com 2 Topside)
Create=3
Port=2002
Baud=115200
Parser=4
;ParserParameters=HEAVESCALE -1

[Serial3]          ; Embedded CPU Com 3 (Com 3 Topside)
Create=2
Port=3
Baud=19200
Parser=9

[Serial4]          ; Embedded CPU Com 4 (Reserved for SV sensor only)
Create=1
Port=4
Baud=19200
Parser=9

;[Serial5]         ; Reserved for Ethernet POSMV Connection
;Create=0
;Port=UDP:5602
;Parser=20
;Network=1

```

Figure A-4: SonarSerial.ini File

Diagnostic Information

Connection to Towfish Electronics Good

Service Flag: 0x30000000 Overflow Count: 0 Done

Power (V): 51.1 Error Count: 58

Ambient (C): 30.0 Resets: 0

Activity: 388216

Time Sync: None

Port1: Port Inactive ← GPS/IMU is DISCONNECTED

Port2: Port Inactive ← IMU/GPS is DISCONNECTED

Port4: Active ← SVS is ON and CONNECTED

Sonar Head is ON and CONNECTED

Figure A-5: Diagnostic Window, Reporting Ports Inactive Error

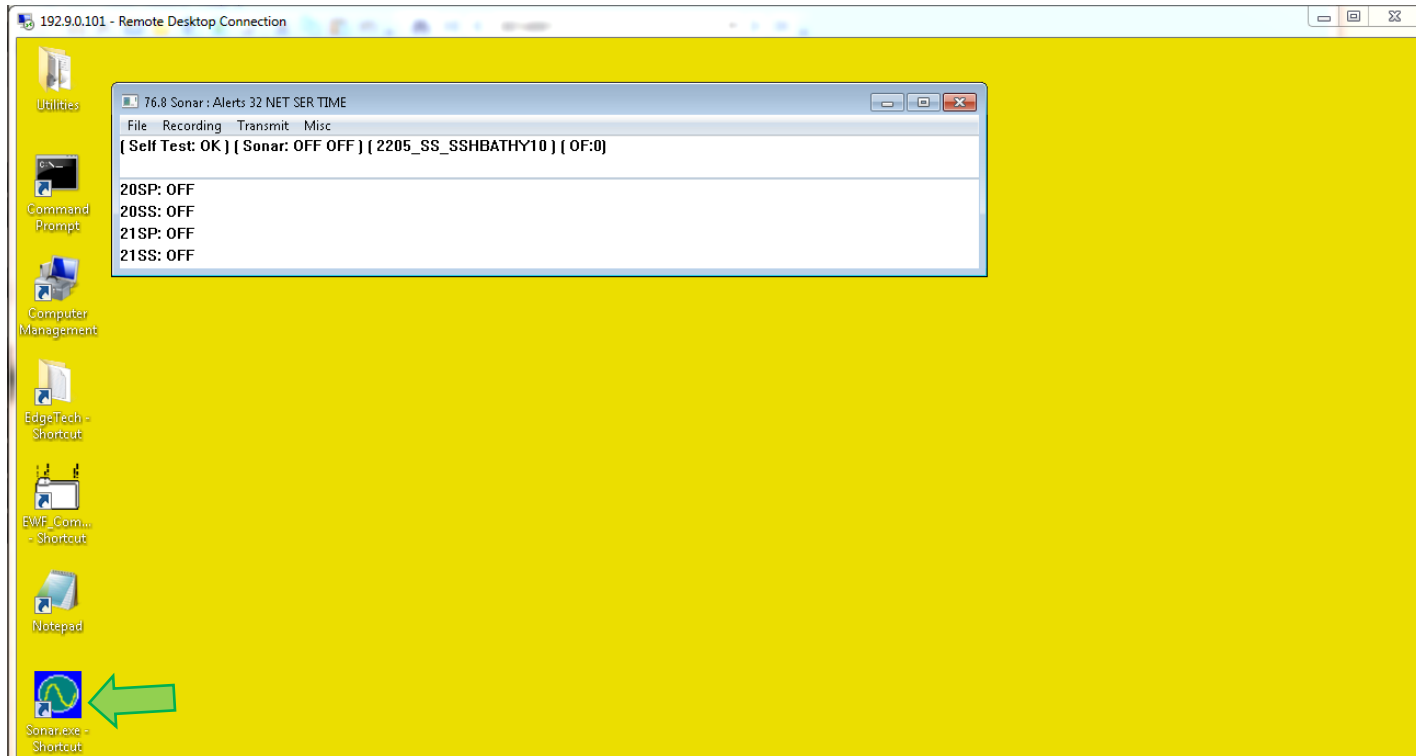

Figure A-6: Rebooting Sonar from the Main Screen

8. Plug the device into COM 1.
9. Click **Misc.** at the top of the Sonar screen, as shown in [FIGURE A-7](#), then **Serial Port Information**.
10. Check COM1 and set the correct baud rate for that device by using the drop-down menu, shown with a blue arrow in [FIGURE A-7](#). When the correct baud rate is set, the State should say **OK** and **Errors** should not be increasing, as shown circled in green, [FIGURE A-7](#). The correct data string should also be scrolling in the lower part of the window, as shown in green arrow, [FIGURE A-7](#).
11. Click **File > Show Status** in the sonar window, as shown circled in red in [FIGURE A-8](#).
12. On the right-hand side of the window, click on the **Config** bullet under the Update button and then on the drop-down menu named **Config Item** (in green).
13. Select **Serial** and then click on the **Update** button several times (blue arrow).
14. Check to make sure the sensor's usage percentage is well below 80% (circled in purple).
 - a. If it is not, increase the baud rate of the sensor. Change the baud rate under Serial Port Information, as shown in step 10. Check the Status again. Otherwise, the sonar will report errors.

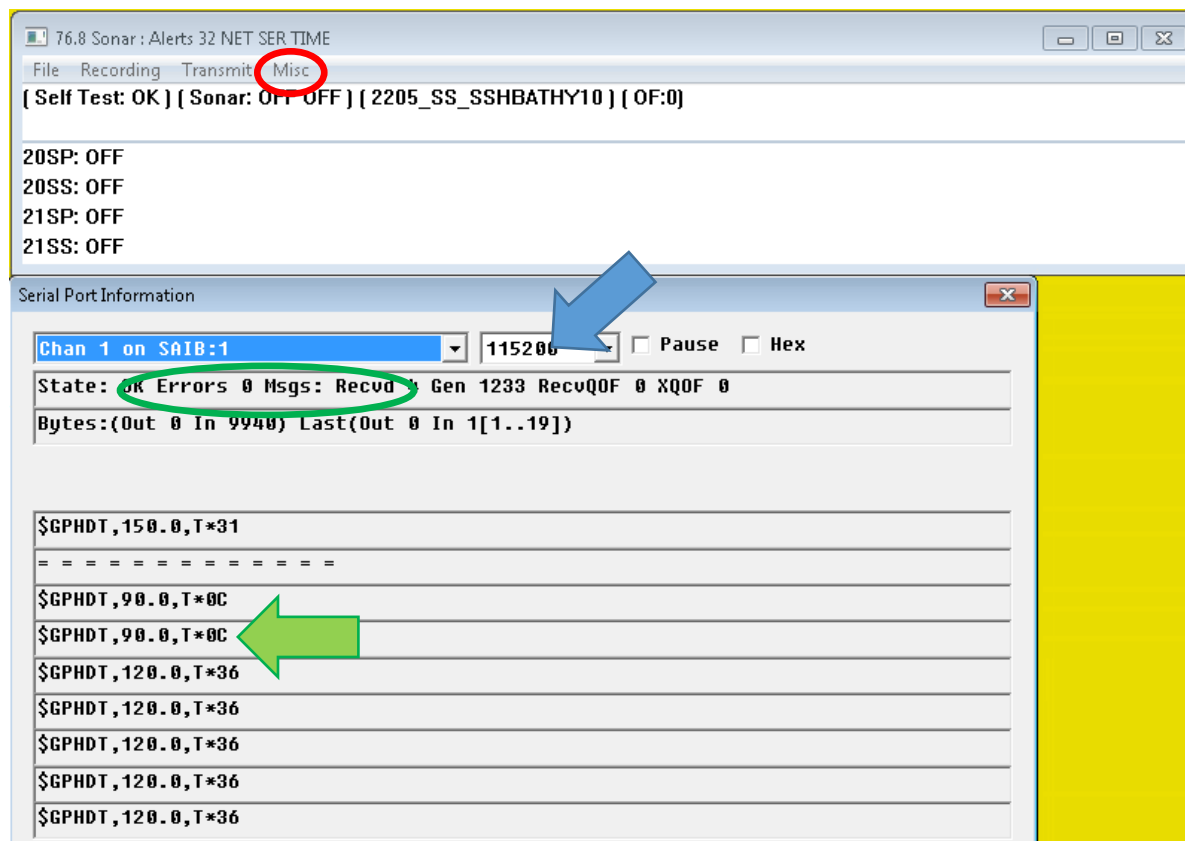

Figure A-7: Checking Serial Port Information

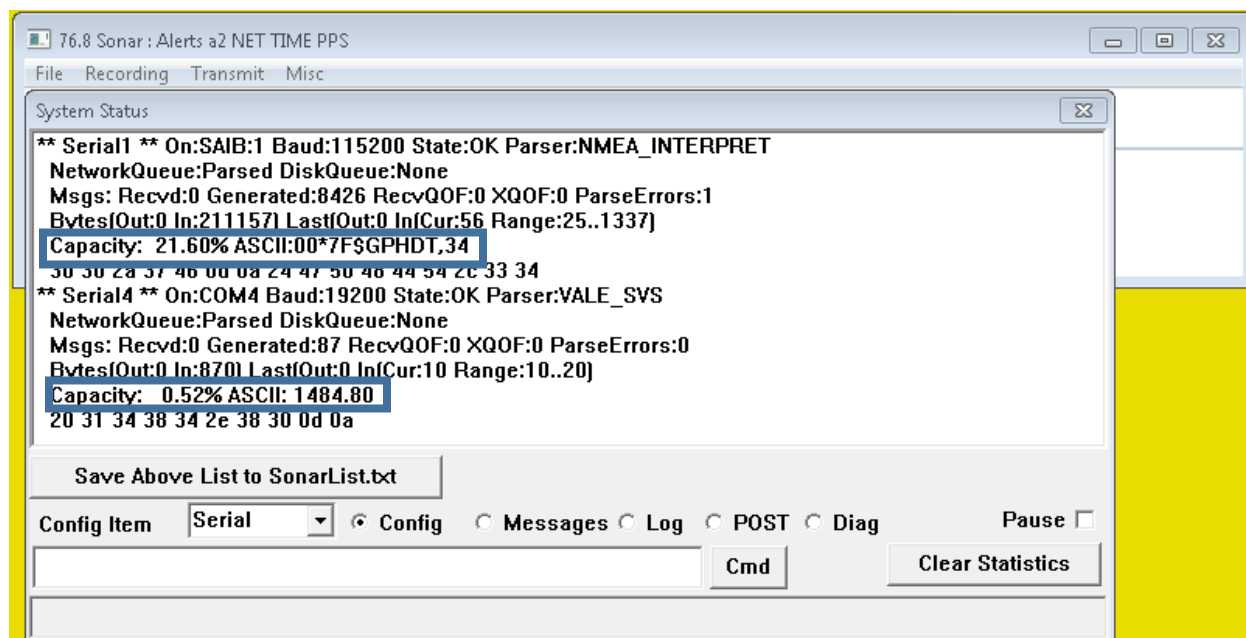

Figure A-8: Checking Sensor Status

15. When satisfied with the incoming data, press OK in the System Status window, shown in **FIGURE A-9**.

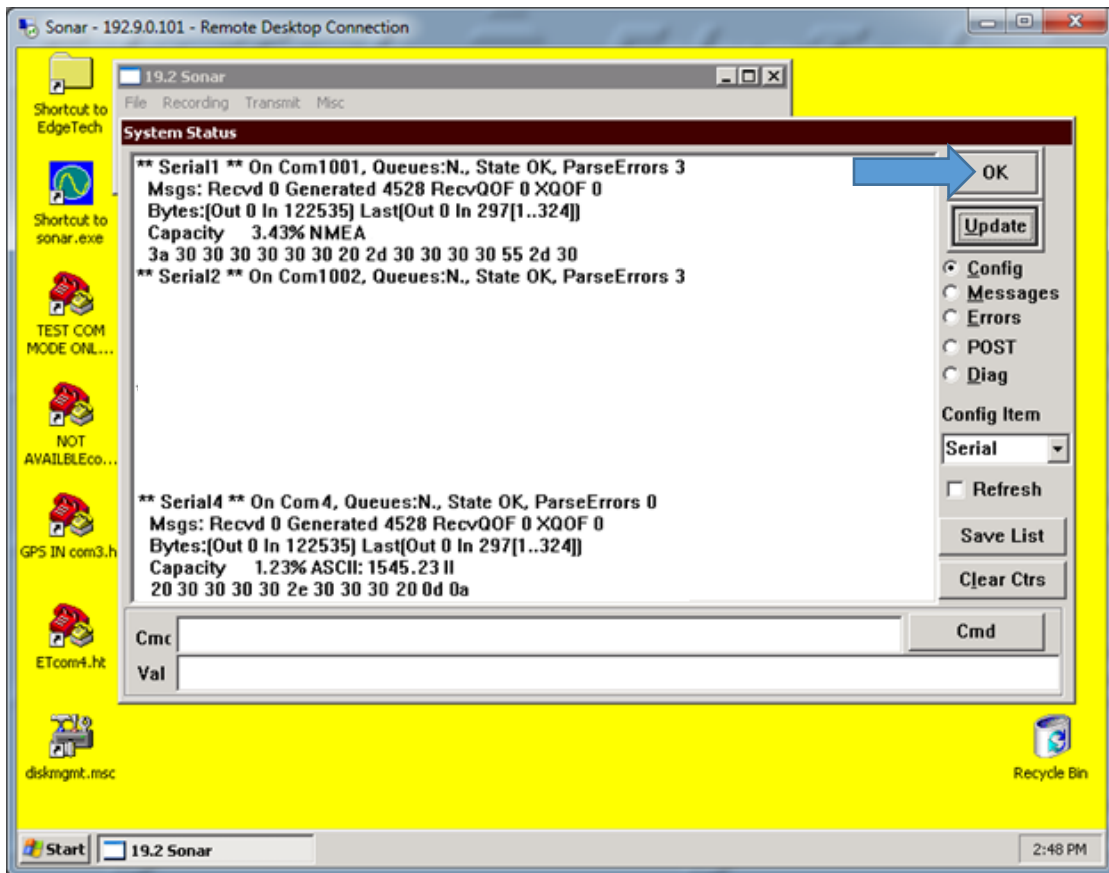

Figure A-9: Closing the System Status Window

16. Finally, close the Sonar - 192.9.0.101 - Remote Desktop Connection window.

NOTE: If this window is left open during data acquisition, the user may experience a very slow computer. This is because the remote desktop application uses a large amount of the link capacity to stay open. So it is always a good idea to close the remote desktop application when finished with configurations.

A.2 Two Sensors

Two sensors, such as a dual-headed GPS (heading, position, and time source) and a Motion Reference Unit (roll, pitch, and heave) may be used to supply the necessary information. For this type of configuration, only COM1 and COM2 will be used.

To configure the COM ports for the two sensors:

1. Follow steps 1 through 6 as stated previously under appendix sub-section **A.1**.
2. Under [Serial3] set Create = 0, select File > Save, and close the file, as shown in **FIGURE A-10**.

CAUTION!

Do not touch anything else or the system's configuration files could be seriously compromised, and functionality may suffer.

This will deactivate COM3. By deactivating this port, Sonar will report to DISCOVER that only two sensors are to be used on COM1 and COM 2 to parse the necessary sensor information. Therefore, DISCOVER will not throw up any errors if a sensor is not connected to COM3.

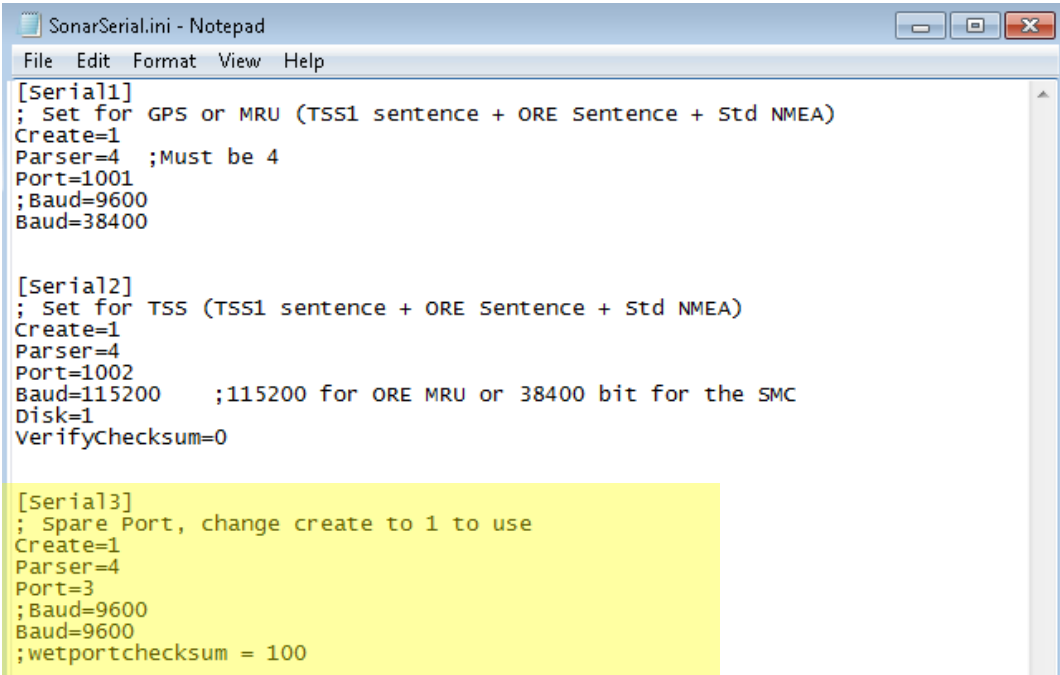

```

[Serial1]
; Set for GPS or MRU (TSS1 sentence + ORE Sentence + Std NMEA)
Create=1
Parser=4 ;Must be 4
Port=1001
;Baud=9600
Baud=38400

[Serial2]
; Set for TSS (TSS1 sentence + ORE Sentence + Std NMEA)
Create=1
Parser=4
Port=1002
Baud=115200 ;115200 for ORE MRU or 38400 bit for the SMC
Disk=1
VerifyChecksum=0

[Serial3]
; Spare Port, change create to 1 to use
Create=1
Parser=4
Port=3
;Baud=9600
Baud=9600
;wetportchecksum = 100

```

Figure A-10: SonarSerial.ini File

3. Reboot the Sonar Firmware by double clicking on the Sonar icon in the main Sonar Remote Desktop Screen, as shown in **FIGURE A-6**, designated by green arrow.
4. Now, plug in the devices into COM 1 and COM 2. Which device is connected to which COM port does not matter, as long as their respective ports and baud rates are set in Sonar.
5. Click on **Misc.** at top of the Sonar screen, as shown in **FIGURE A-7**, then **Serial Port Information**.
6. Check COM1 and set the correct baud rate for that device by using the drop-down menu shown in blue, as shown in **FIGURE A-7**. When the correct baud rate is set, the State should say **OK** and

Errors should not be increasing, as shown in **FIGURE A-7**, circled in green. The correct data string should also be scrolling in the lower part of the window, as shown in **FIGURE A-7**, green arrow.

7. Now Check COM2 and set the correct baud rate for the other device as done before in Step 6.
8. Now click on **File > Show Status** in the sonar window, as shown circled in red in **FIGURE A-11**.
9. On the right-hand side of the window, click on the **Config** bullet under the **Update** button and then on the drop-down menu named **Config Item**, as shown in **FIGURE A-11**, green.
10. Select **Serial**, then click on the **Update** button several times, as shown in **FIGURE A-11**, blue arrow.
11. Check to make sure sensors' usage percentages are well below 80%, as shown in **FIGURE A-11**, circled in purple. If they are not, increase sensor's baud rate. Change baud rate under **Serial Port Information** as done in steps 6 and 7. Check **Status** again. Otherwise, sonar will report errors.

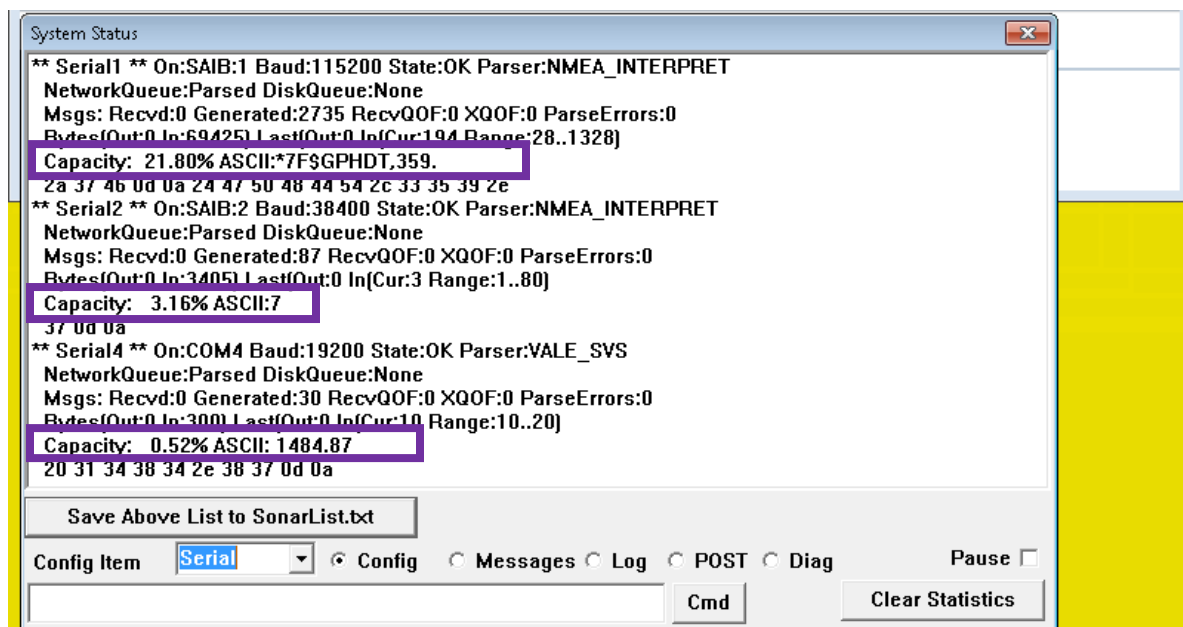

Figure A-11: Checking Sensors' Usages

12. When satisfied with incoming data, press **OK** in 'System Status' window, as shown in **FIGURE A-11**.
13. Finally, close the Sonar - 192.9.0.101 - Remote Desktop Connection window.

NOTE: If this window is left open during data acquisition, you may experience a very slow computer because the Remote Desktop uses a large amount of the link capacity to stay open. It is always wise to close the Remote Desktop when finished with the configurations.

A.3 Three Sensors

Three sensors, such as a gyro (heading), a GPS (position, and time source), and a Motion Reference Unit (roll, pitch, and heave) may be used to supply the necessary information. For this type of configuration, all available COM ports will be used.

To configure the COM ports for the three sensors, the following steps should be carried out.

1. Follow steps (1.) through (6.) as stated previously under appendix sub-section **A.1**.
2. Make sure Create=1 under each [Serial#], as shown in **FIGURE A-12**.

```

[Serial1]
; Set for GPS or MRU (TSS1 sentence + ORE Sentence + Std NMEA)
Create=1
Parser=4 ;Must be 4
Port=1001
;Baud=9600
Baud=38400

[Serial2]
; Set for TSS (TSS1 sentence + ORE Sentence + Std NMEA)
Create=1
Parser=4
Port=1002
Baud=115200 ;115200 for ORE MRU or 38400 bit for the SMC
Disk=1
VerifyChecksum=0

[Serial3]
; Spare Port, change create to 1 to use
Create=1
Parser=4
Port=3
;Baud=9600
Baud=9600
;wetportchecksum = 100

[Serial4] ;Dont touch ever or there will be no sound velocity data
; Com4 set for valeport MinisVS
; Setup: Using the vendor provided configuration utility, set the following:
; Baud: 19200
Create=1
Parser=9
Port=4
Baud=19200

```

Figure A-12: All Sensors Set

3. Select File > Save and close the file.

CAUTION!

Do not touch anything else or the system's configuration files could be seriously compromised, and functionality may suffer.

4. Close the SonarSerial.ini file and reboot the Sonar Firmware by double clicking on the Sonar icon in the main Sonar Remote Desktop Screen, as shown in **FIGURE B-6**, designated by the green arrow.
5. Now, plug in the devices into COM 1, COM 2, and COM 3. The Gyro should be connected to COM1, the MRU COM2, and the GPS to COM3. The devices connected to COM1 or COM2 may be interchanged but the GPS must be connected to COM3.
6. Click **Misc.** at top of Sonar screen, as shown in **FIGURE A-7**, then **Serial Port Information**.
7. Check COM1 and set the correct baud rate for that device by using the drop-down menu shown in blue, as shown in **FIGURE A-7**. When the correct baud rate is set, the **State** should say **OK** and **Errors** should not be increasing, as shown in **FIGURE A-7**, circled in green. The correct data string should also be scrolling in the lower part of the window, as shown in **FIGURE A-7**, green arrow.
8. Now check COM2 and set the correct baud rate for the other device as done before in Step 6.
 - a. Remember to check COM3 as before and set the correct baud rate for GPS.
9. Click on **File > Show Status** in the sonar window, as shown in **FIGURE A-8**, circled in red.
10. On the right-hand side of the window, click on the **Config** bullet under the **Update** button, and then on the drop-down menu named **Config Item**, as shown in **FIGURE A-8**, green.
11. Select Serial, then click on the Update button several times, as shown in **FIGURE A-13**, blue arrow.
12. Check to make sure sensors' usage percentages are well below 80%, as shown in **FIGURE A-13**, circled in purple. If they are not, increase sensor's baud rate. Change baud rate under Serial Port Information as done in steps 6 and 7. Check Status again, otherwise sonar will report errors.
13. When satisfied with incoming data, press **OK** in 'System Status' window, as shown in **FIGURE A-13**.
14. Finally, close the Sonar - 192.9.0.101 - Remote Desktop Connection window.

NOTE: If this window is left open during data acquisition, the user may experience a very slow computer. This is because the remote desktop application uses a large amount of the link capacity to stay open. So it is always a good idea to close the remote desktop application when finished with the configurations.

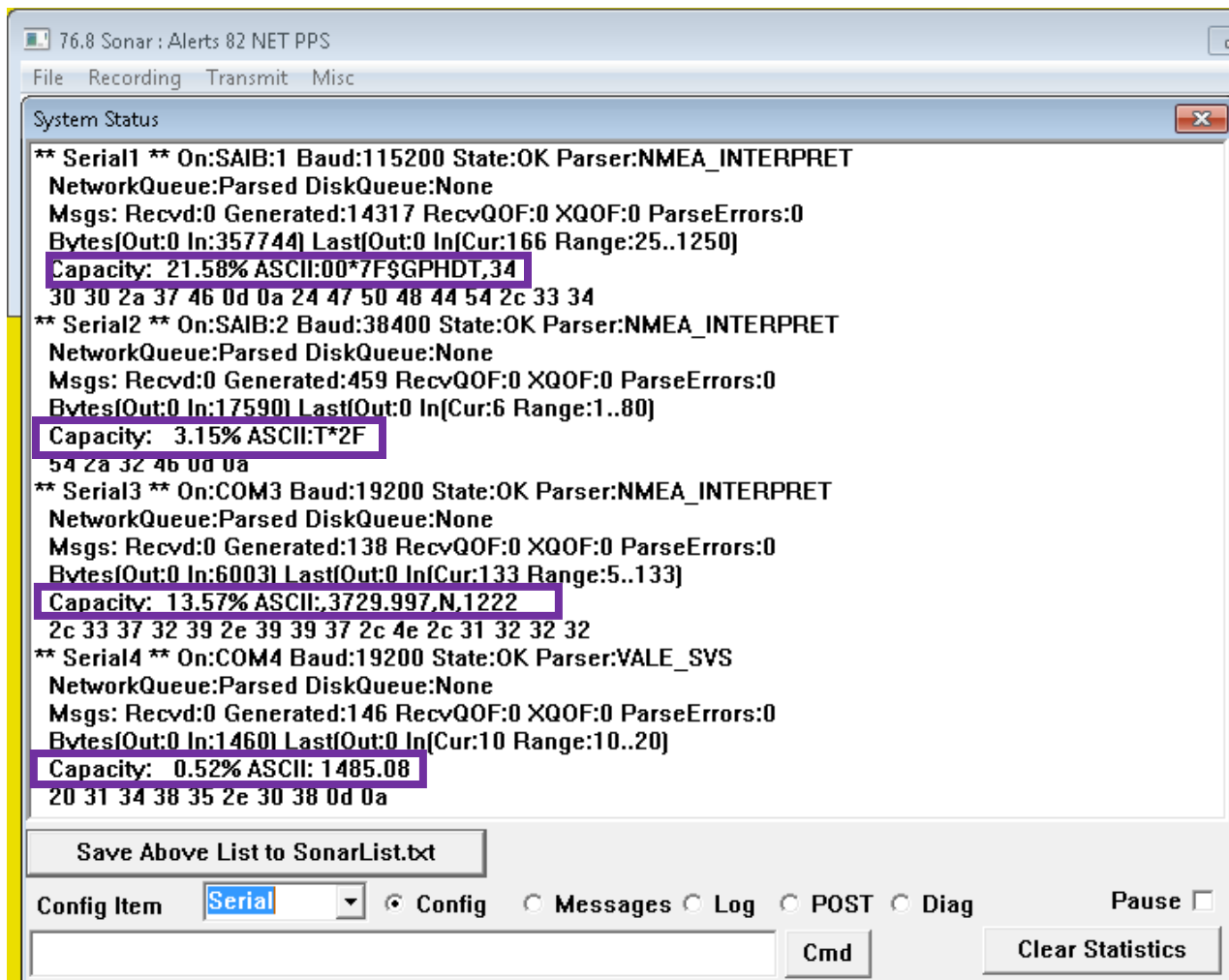

Figure A-13: Checking all COM Ports

CAUTION! EdgeTech recommended performing the process described in the section below through DISCOVER, but the process below provides an alternative. Please refer to the DISCOVER BATHYMETRY Manual for information on how to complete this process in DISCOVER.

A.4 UDP Connections

The 6205s is compatible with data sent over the Ethernet connection via UDP. The SonarSerial.ini is utilized to configure the system to accept these messages. Note that 1PPS functionality must be utilized when operating with attitude / NAV being transferred with UDP messages.

All messages detailed in Section 3.1 can also be sent to the 6205s over the Ethernet connection via UDP. The below example shows the same configuration detailed in [FIGURE A-14](#) but with UDP functionality.

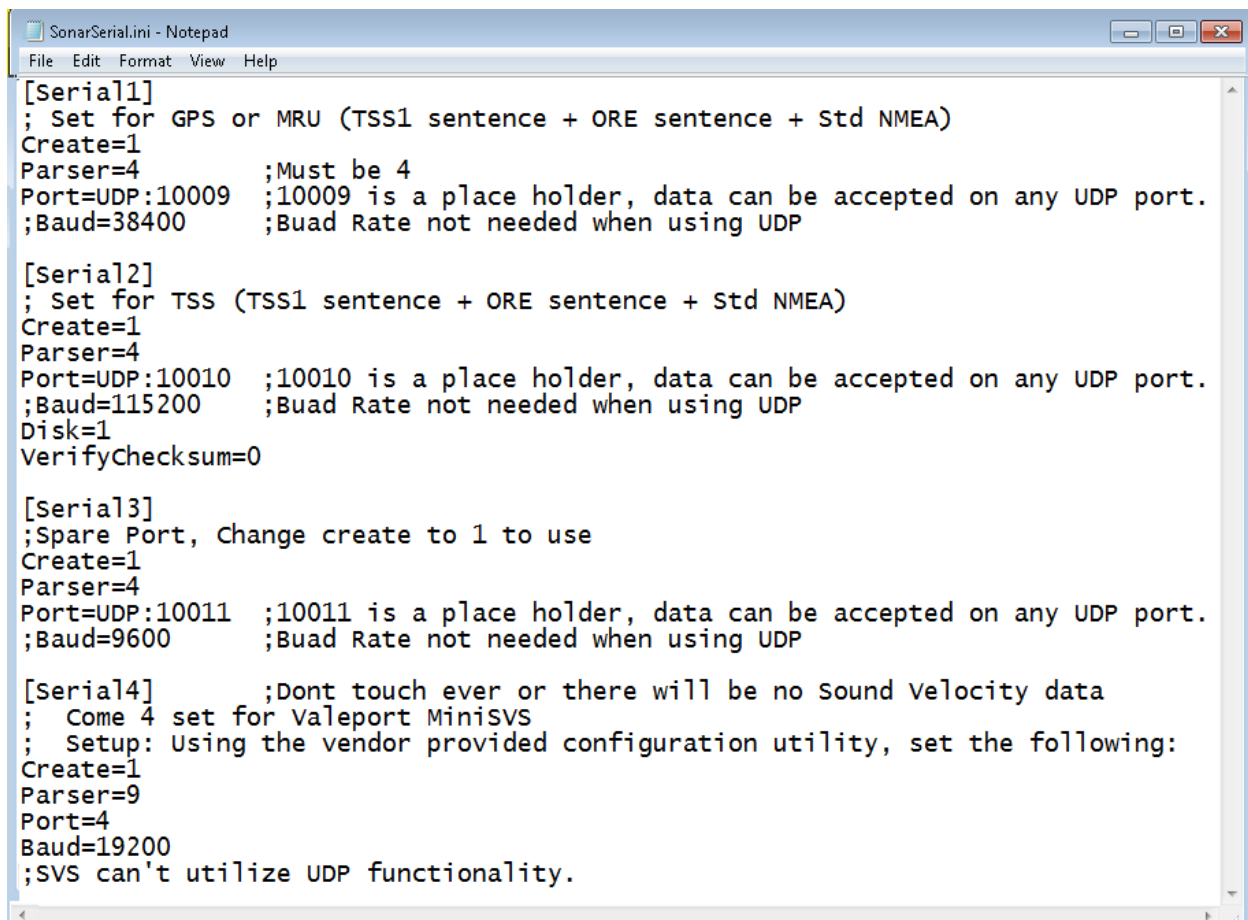

```
[Serial1]
; Set for GPS or MRU (TSS1 sentence + ORE sentence + Std NMEA)
Create=1
Parser=4 ;Must be 4
Port=UDP:10009 ;10009 is a place holder, data can be accepted on any UDP port.
;Baud=38400 ;Buad Rate not needed when using UDP

[Serial2]
; Set for TSS (TSS1 sentence + ORE sentence + Std NMEA)
Create=1
Parser=4
Port=UDP:10010 ;10010 is a place holder, data can be accepted on any UDP port.
;Baud=115200 ;Buad Rate not needed when using UDP
Disk=1
VerifyChecksum=0

[Serial3]
;Spare Port, change create to 1 to use
Create=1
Parser=4
Port=UDP:10011 ;10011 is a place holder, data can be accepted on any UDP port.
;Baud=9600 ;Buad Rate not needed when using UDP

[Serial4]
; Dont touch ever or there will be no sound velocity data
; Come 4 set for Valeport MiniSVS
; Setup: Using the vendor provided configuration utility, set the following:
Create=1
Parser=9
Port=4
Baud=19200
;SVS can't utilize UDP functionality.
```

Figure A-14: UDP Configuration Example

CAUTION! EdgeTech recommended performing the process described in the section below through DISCOVER, but the process below provides an alternative. Please refer to the DISCOVER BATHYMETRY Manual for information on how to complete this process in DISCOVER.

A.5 POSMV Configuration

The 6205s is compatible with the POSMV system from Applanix. Follow the below steps to configure the 6205s and the POSMV for communication over the Ethernet interface via UDP.

To configure the COM ports for the UDP messages from the POSMV:

1. Follow steps 1 through 5 as stated previously under appendix sub-section B.1
2. Under [Serial1], [Serial2], and [Serial3] set Create = 0.
3. Under [Serial5], set Create = 1 and remove semicolon from the beginning of each line in [Serial5] section.
4. Ensure the command Parserparameters=HEAVESCALE -1.0 is present in the [Serial5] section. If it is not present, add it.

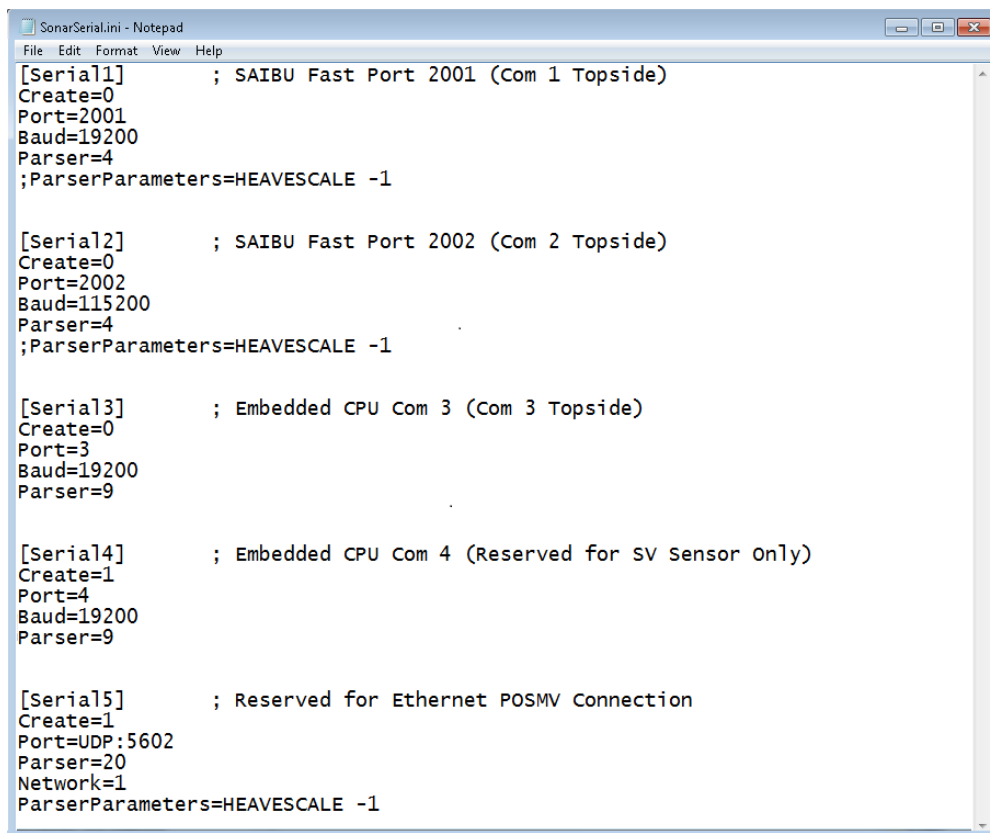

```

SonarSerial.ini - Notepad
File Edit Format View Help
[Serial1]          ; SAIBU Fast Port 2001 (Com 1 Topside)
Create=0
Port=2001
Baud=19200
Parser=4
;ParserParameters=HEAVESCALE -1

[Serial2]          ; SAIBU Fast Port 2002 (Com 2 Topside)
Create=0
Port=2002
Baud=115200
Parser=4
;ParserParameters=HEAVESCALE -1

[Serial3]          ; Embedded CPU Com 3 (Com 3 Topside)
Create=0
Port=3
Baud=19200
Parser=9

[Serial4]          ; Embedded CPU Com 4 (Reserved for SV Sensor Only)
Create=1
Port=4
Baud=19200
Parser=9

[Serial5]          ; Reserved for Ethernet POSMV Connection
Create=1
Port=UDP:5602
Parser=20
Network=1
ParserParameters=HEAVESCALE -1

```

Figure A-15: POSMV UDP Configuration

CAUTION!

Do not alter the file in any way other than what has been specified.

This will deactivate COM ports 1, 2, and 3 while activating COM 5 which has been pre-configured for POSMV functionality. Therefore, Discover will not throw up any errors if a sensor is not connected to COM1, COM2, or COM3.

To configure the time synchronization sources:

1. Locate and open the SonarConfig.ini file. This file is located in the same directory as the SonarSerial.ini file which was modified above.
2. This file points the software to the correct configuration file based off the frequency set of the hardware in use. Locate the [Main] section and take note of the .ini file being called out. As an example: the below file specifies the system is a 520kHz / 1600kHz Side Scan with 520kHz Bathymetry and as such utilizes the sonar_520B_1610.ini.

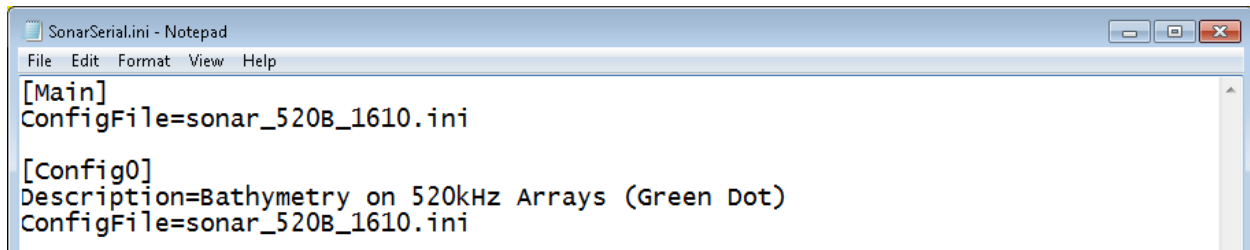

Figure A-16: SonarConfig.ini Example

3. Close the SonarConfig.ini without making any changes to the text.
4. Open the file name specified in the SonarConfig.ini, it can be found in the same directory.
5. In the [Main] section of this file, comment out the current TimeSyncSource command line (default is TimeSyncSource=ZDA) by adding a ";" in front of the keyword.
6. Under commented out TimeSyncSource line add the following: TimeSyncSource=POSMV_Binary. Ensure there is no semicolon in front of this iteration of the keyword.

```

;TimeSyncSource=ZDA
TimeSyncSource=POSMV_BINARY

```

Figure A-17: TimeSyncSource Keyword Adjustments

7. In the [DSP0] section of this file, ensure the TimeSyncMask keyword is set to the following: TimeSyncMask=4. Ensure there is no semicolon in front of the keyword.

8. Select File > Save and close the text document.

CAUTION!

Do not alter the file in any way other than what has been specified.

This sets the software to utilize the time and date reference being received from the POSMV data string. It also activates the 1PPS port on the topside module. A 1PPS sync must be utilized when data is being received via UDP due to the inherent added latency.

When the above steps have been completed Sonar.exe must be re-launched to activate the configuration changes. This can be completed via the “x” in the top right-hand corner of the Sonar.exe GUI and the Sonar.exe shortcut on the desktop of the embedded CPU.

Utilizing the POSVIEW software set the ethernet real-time to groups 3,7,10, and 102. The output rate of the POSMV module should be set to 50Hz. The POSMV must also be set to Falling (Negative) Edge or **Active Low** for the 1PPS as the 6205s defaults to sync on the falling edge

Once the configuration of both devices is completed the Sonar Serial Port Viewer can be utilized to confirm data is being accepted correctly. To access this, select the Misc. tab in the Sonar.exe GUI (as shown in Figure B-7), then **Serial Port Information**. Select Com5 in the first dropdown, ensure data is being received and the State is being reported as “OK”.

Discover Bathymetry can also be utilized to check for correct configuration of the two units. The diagnostic window as shown in Figure B-5 should not report any errors. If errors are seen review all changes made in the above section. If errors persist contact [EDGE TECH CUSTOMER SERVICE](#).

APPENDIX B: SOFTWARE

B.1 DISCOVER BATHYMETRIC

EdgeTech's DISCOVER BATHYMETRIC Software provides a way to control, store, and display Bathymetric and Dual-Frequency Side Scan Sonar data. Data is presented in a color waterfall display and stored in the binary EdgeTech JSF file format on the hard disk of the Topside Processor. The JSF file format has been in use for 10+ years and has new public extensions to support the additional Bathymetry data messages. Refer to the **DISCOVER BATHYMETRIC Software** Manual for a full description of its feature and functions (0014878).

B.2 Third Party Software

Currently, there are several Third-Party software packages that have been approved by EdgeTech to use with the 6205s System, and work continues to expand the number of available topsides. A brief description is listed below. For the latest list of Third-Party topsides, contact **EDGETECH CUSTOMER SERVICE**.

B.2.1 HYPACK

The processed bathymetry and side scan data is sent in real-time to the HYPACK®/HYSWEEP® survey applications. These applications display and record the bathymetric data in HYPACK's HSX format. These HSX files can then be used off line in the MBMax, Side Scan Mosaic, and other proprietary packages that support these formats to edit, clean, and mosaic the collected data.

For more information on Hypack, visit: <http://www.hypack.com/new/>

B.2.2 SonarWiz

SonarWiz from Chesapeake Technologies Inc. is an all-in-one suite of programs for real-time acquisition of sonar data. The latest version of SonarWiz, called SonarWiz 5, now offers a bathymetry module to acquire and post process the real time 6205s Swath Bathymetry and Dual Frequency Side Scan data. The latest release also has the ability to ingest the native EdgeTech JSF files post survey in order to post process the sonar data files recorded by DISCOVER BATHYMETRIC.

For more information on SonarWiz, visit: <http://www.chesapeaketech.com/products/sonarWiz-5.php>

B.2.3 QINSy

QINSy is a hydrographic data acquisition, navigation, and processing software package. The suite of applications can be used for various types of surveys, ranging from simple single beam surveys up to complex offshore construction works.

For more information on QINSy, visit: <http://www.qps.nl/display/qinsy/main>

B.2.4 CARIS

CARIS HIPS and SIPS is a comprehensive Bathymetric, seafloor imagery, and water column data-processing software. The HIPS and SIPS software enables the user to simultaneously process multibeam, backscatter, side scan sonar, LiDAR, and single beam data. With its latest importer, released in July 2014, it now supports EdgeTech's bathymetry and side scan data formats.

For more information on CARIS, visit: <http://www.caris.com/>

B.2.5 EIVA NaviSuite

EIVA's NaviSuite constitutes a complete, advanced, multipurpose suite of software products for virtually any subsea sonar and sensor survey or engineering operation. From online data acquisition to offline post-processing, NaviSuite covers the entire data workflow in a continuous, non-sequential process.

For more information on EIVA and, visit: <http://www.eiva.com/products/software>

APPENDIX C: SYSTEM RESTORE

This section outlines the procedures for backing up and restoring the optional EdgeTech supplied Laptop crash. If the user experiences any issues, contact [EDGE TECH CUSTOMER SERVICE](#) immediately so we can help restore the system and get the survey back up and running as soon as possible.

CAUTION!

All data will be lost upon restoring the system to factory settings. Be sure to backup all data before performing the procedure below.

1. Ensure that topside is off.
2. Insert USB3 flash drive in blue USB3 port.
3. Start topside and be prepared to press **F**** key when prompted:
 - a. If the topside is rack mount, press **F11**.
 - b. If the topside is a laptop, press **F12**.
4. Under **select boot device**: By using up/down arrow keys, select **EUFi: Corsair Voyager 3.0 000A**, then press **Enter**.
5. Wait for **Paragon Backup & Recovery 14 Home** screen to appear, then click **Restore** icon.
6. On **Welcome to the Restore Wizard** screen click **Next**.
7. On **Browse for Archive** screen, drag down menu and click on  to the left of **(E:)**. Click on folder named as a variation of **V*.*.*)_****R** for rack mounts, or **V*.*.*)_****P** for laptops. When **Archive File Details** window appears, click **Next**.
8. At **What to restore** window, click **Basic MBR Hard Disk 0**, click **Next**.
9. At **Where to restore** window, ensure that **Basic MBR Hard Disk 0** is already selected (brown box around it). If it is not, use up/down arrow keys to select. Click **Next**.
10. At **Restore results** window, make no selection and click **Next**.
11. At the **Ready to restore from the archive** window, select **Yes, apply the changes physically**. Click **Next**. *Restoring will begin.*
12. At **Completing the restore wizard**, click **Finish**. Click **Shutdown**.
13. Remove USB3 flash drive and restart topside.