

TCU 6ch

6 station Tool Control Unit

innova.no

Part number: 5019608

Subsea valve pack with 6 channels with bidirectional, proportional directional controlled valves.

Each channel features proportional pressure control with individual pressure sensor.

Inlet oil pressure and temperature as well as return oil pressure are also monitored.

Valve control and communication is provided by 2 off Innova's PIO36 pressure tolerant controller boards, enabling full control of the valve pack via serial or Ethernet network (Modbus RTU or TCP).

Innova's topside GUI software is used to control and monitor all functions of single or multiple valve packs. The valve packs can also easily integrate into Client's existing control system.

Key features

6 off 4/3-way valves

- Flow, directional and pressure control
- Individual pressure monitoring on each port
- Temperature sensor
- 3000 m seawater depth rating
- Interface for Oceaneering torque tool

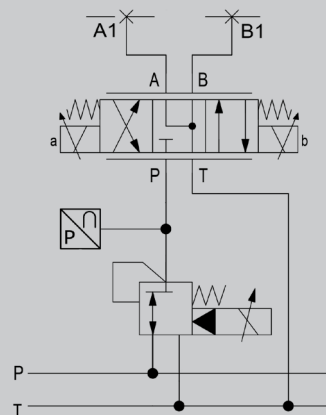

HYDRAULIC FUNCTIONS

6 off 4/3-way NG6 control valves

- Maximum Working Pressure = 250bar
- Valve max flow = 40 lpm
- Pressure transmitters on P and T ports and at each port

INTERFACE

- G1/2 hydraulic supply port (P)
- G3/4 hydraulic return port (T)
- G1/2 hydraulic outlets ports (A/B)
- 1/4" SWAGELOK QUICK CONNECTOR for filling and draining of compensation fluid
- G3/8 for comp. relief valve
- G3/8 pressure transmitter port
- 1 x 5506-2013 Connector for power and communication
- 1 x connector for interfacing Oceaneering torque tool



valve pack with accessories

ELECTRICAL

- Innova PIO36 pressure tolerant embedded controller
- Ethernet, RS-232 or RS-485 communication link
- Max power consumption: 10 A @ 24 VDC
- Water alarm
- Temperature sensor
- 110 / 230 VAC (optional)
- Seal test port (optional)

MECHANICAL

- Hard anodized aluminium and POM housing
- Polycarbonate lid
- Weight in air: 63 kg - In water: 46 kg (excl. comp. fluid)
- L x W x H: 494 x 345 x 265 mm (excl. connectors)
- Pressure compensator included
- 3000 m seawater depth rating
- Temperature range: -18 °C to 40 °C
- Delivered in a transport case, together with PC, GUI Software and required accessories

SOFTWARE

Delivered with standard Innova software with graphical user interface to control each valve, read sensor values, calibrate sensors and log data.

Our software engineers will also assist integration with existing control systems on request.

