



SERIES 70 10K PSI / 700 BAR / 7000 M
**SeaKing™ High-Pressure Subsea
 Connectors, Cables, and PBOF Assemblies**
 PBOF assembly fittings and accessories



REVOLUTIONARY PBOF SWIVEL HOSE ATTACHMENT ACCESSORIES

Hose barb fittings for PBOF assemblies are the perennial weak link in subsea oil & gas applications. Kinked and twisted hoses, leaky fittings, corroded hose clamps, and general poor performance characterize most existing solutions. The Glenair PBOF swivel hose attachment for SeaKing™ connectors solves these problems and more. Designed from the sea floor up to perform flawlessly and reliably, this revolutionary attachment puts an end to the long list of field maintenance problems associated with oil-filled cable applications.

- **Straight, 45°, and 90° “full radius” angle and profile hose routing**
- **Hose angle adjustment feature eliminates risk of oil leakage**
- **Corrosion-resistant materials used throughout**
- **Threaded couplers with safety set-screws for fail-safe leak and decoupling protection—no special tools required for assembly**
- **Compact PBOF compression fitting with 340° hose swivel action**
- **Support for the broad range of hose diameters and wall thicknesses**



interlocking teeth

Interlocking teeth on SeaKing™ plug connectors interface with corresponding teeth on the PBOF swivel hose attachment to facilitate easy indexing and routing of hose assemblies

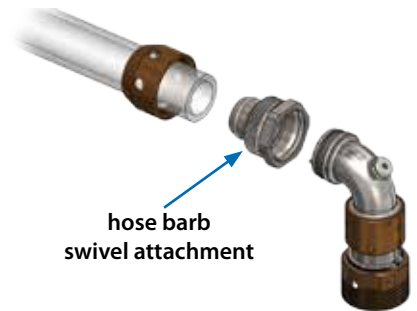

hose barb swivel attachment

Revolutionary swivel hose barb compression attachment eliminates twisting and damage in PBOF assemblies

SUBSEA/DEEPWATER: SEAKING™

SeaKing PBOF Attachment Accessory Kits - How To Order	
Sample Part Number	709-003 K -L 1 S
Product Series	709-003 = SeaKing™ PBOF accessory
Shell Size	G, K, M, O, Q
Angular Function	L = Straight M = 45° N = 90°
Fill Port Option	0 = No fill port 1 = With fill port
Swivel/Fixed Option	S = Swivel F = Fixed

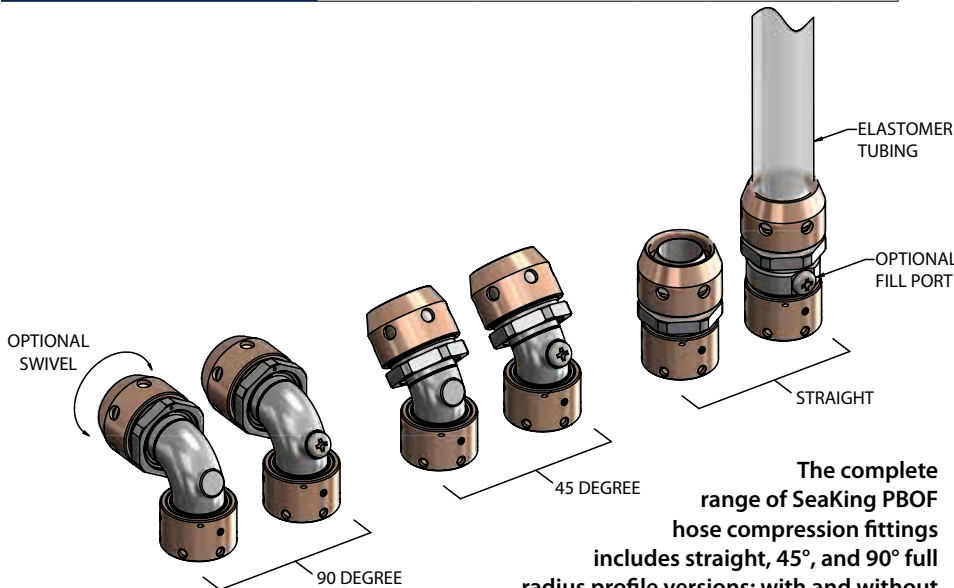

The complete range of SeaKing PBOF hose compression fittings includes straight, 45°, and 90° full radius profile versions; with and without integrated oil fill ports

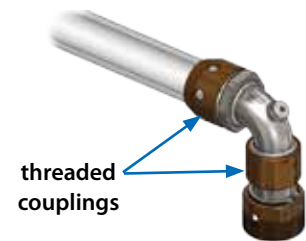

threaded couplings

Threaded PBOF compression nut and connector coupling nut (with additional safety set screw) provide for fast and easy assembly and prevent leaks and assembly decoupling



SERIES 70 10K PSI / 700 BAR / 7000 M
**SeaKing™ High-Pressure Subsea
 Connectors, Cables, and PBOF Assemblies**
 PBOF fitting: straight with fill port and swivel

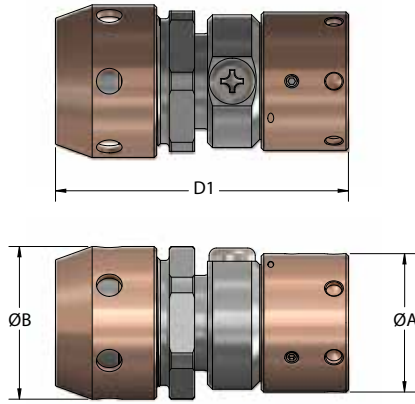

709-003 -L1S
 STRAIGHT, WITH FILL PORT, SWIVEL

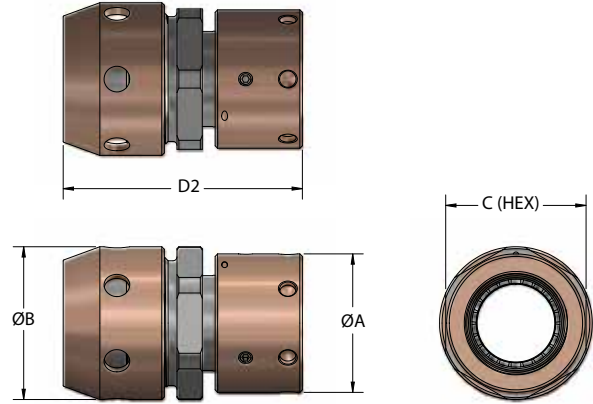

709-003 -L0S
 STRAIGHT, WITHOUT FILL PORT, SWIVEL

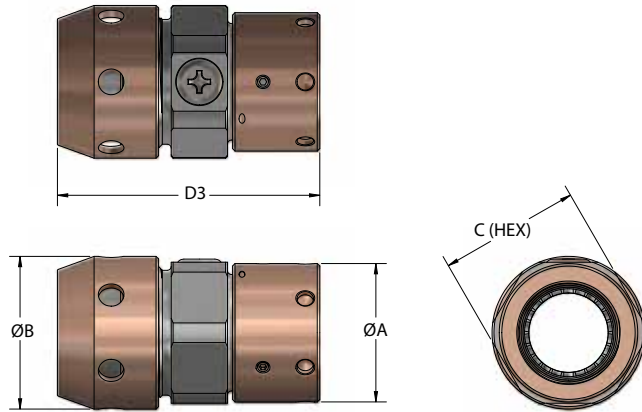

709-003 -L1F
 STRAIGHT, WITH FILL PORT, FIXED

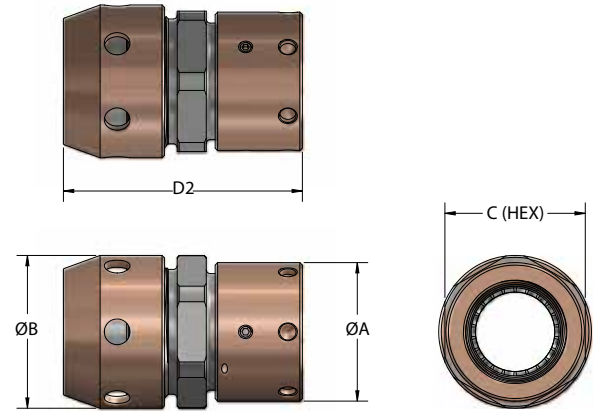

709-003 -L0F
 STRAIGHT, WITHOUT FILL PORT, FIXED

SUBSEA/DEEPWATER: SEAKING™



Dimensions					
Dim Callout	Shell Size				
	G	K	M	O	Q
A	0.97 (24.64)	1.10 (27.94)	1.35 (34.29)	1.60 (40.64)	1.85 (46.99)
B	1.08 (27.43)	1.21 (30.73)	1.40 (35.56)	1.58 (40.13)	1.83 (46.48)
C	0.99 (25.15)	1.11 (28.19)	1.30 (33.02)	1.49 (37.85)	1.80 (45.72)
D1	2.32 (58.93)	2.32 (58.93)	2.40 (60.96)	2.32 (58.93)	2.41 (61.21)
D2	1.89 (48.01)	1.89 (48.01)	1.97 (50.04)	1.89 (48.01)	1.98 (50.29)
D3	2.08 (52.83)	2.08 (52.83)	2.16 (54.86)	2.08 (52.83)	2.08 (52.83)



SERIES 70 10K PSI / 700 BAR / 7000 M
**SeaKing™ High-Pressure Subsea
 Connectors, Cables, and PBOF Assemblies**
 PBOF fitting: 45° with fill port and swivel

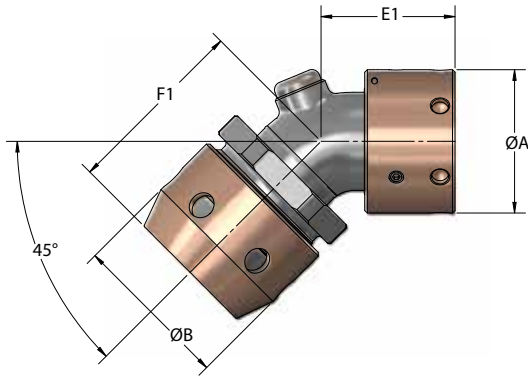

709-003 -M1S
 45°, WITH FILL PORT, SWIVEL

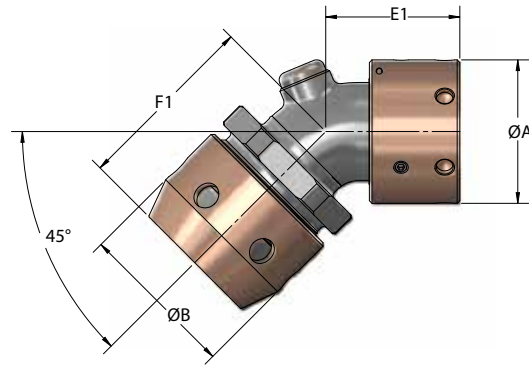

709-003 -M1F
 45°, WITH FILL PORT, FIXED

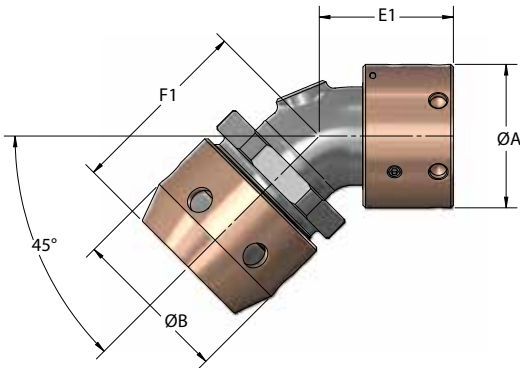
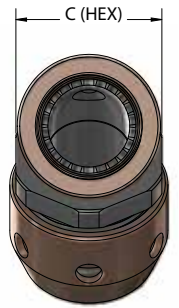

709-003 -M0S
 45°, WITHOUT FILL PORT, SWIVEL

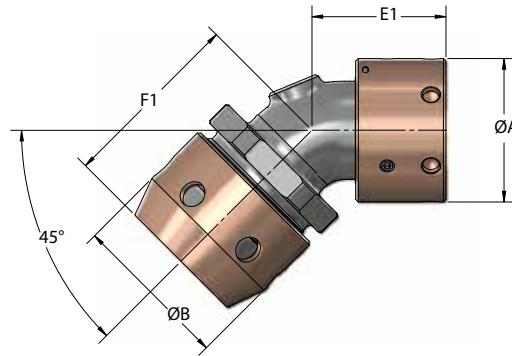

709-003 -M0F
 45°, WITHOUT FILL PORT, FIXED

SUBSEA/DEEPWATER: SEAKING™

Dimensions					
Dim Callout	Shell Size				
	G	K	M	O	Q
A	0.97 (24.64)	1.10 (27.94)	1.35 (34.29)	1.60 (40.64)	1.85 (46.99)
B	1.08 (27.43)	1.21 (30.73)	1.40 (35.56)	1.58 (40.13)	1.83 (46.48)
C	0.99 (25.15)	1.11 (28.19)	1.30 (33.02)	1.49 (37.85)	1.80 (45.72)
E1	1.01 (25.65)	1.07 (27.18)	1.14 (28.96)	1.22 (30.99)	1.33 (33.78)
F1	1.42 (36.07)	1.48 (37.59)	1.63 (41.40)	1.63 (41.40)	1.83 (46.48)



SERIES 70 10K PSI / 700 BAR / 7000 M
**SeaKing™ High-Pressure Subsea
 Connectors, Cables, and PBOF Assemblies**
 PBOF fitting: 90° with fill port and swivel

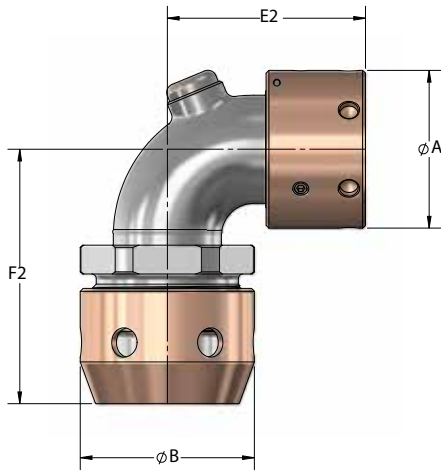

709-003 -N1S
 90°, WITH FILL PORT, SWIVEL

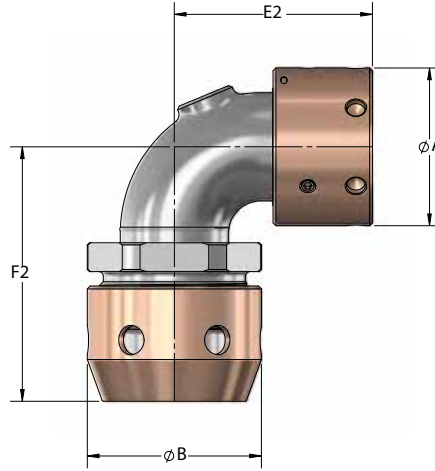

709-003 -N0S
 90°, WITHOUT FILL PORT, SWIVEL

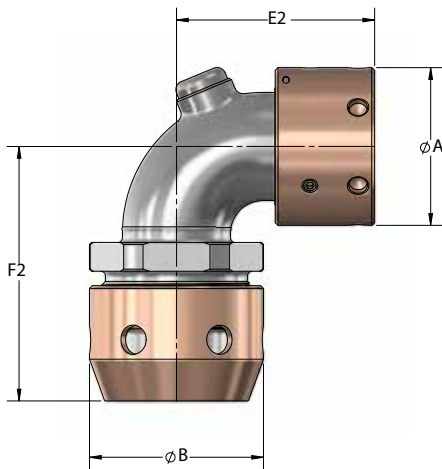
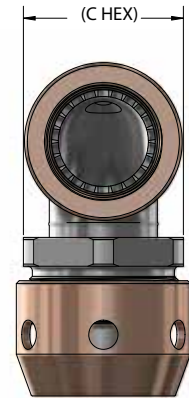

709-003 -N1F
 90°, WITH FILL PORT, FIXED

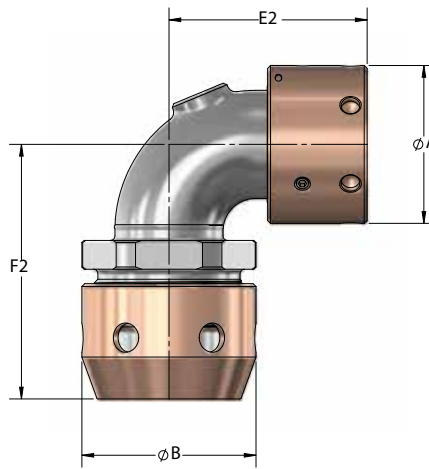

709-003 -N0F
 90°, WITHOUT FILL PORT, FIXED

SUBSEA/DEEPWATER: SEAKING™



Dimensions					
Dim Callout	Shell Size				
	G	K	M	O	Q
A	0.97 (24.64)	1.10 (27.94)	1.35 (34.29)	1.60 (40.64)	1.85 (46.99)
B	1.08 (27.43)	1.21 (30.73)	1.40 (35.56)	1.58 (40.13)	1.83 (46.48)
C	0.99 (25.15)	1.11 (28.19)	1.30 (33.02)	1.49 (37.85)	1.80 (45.72)
E2	1.24 (31.50)	1.36 (34.54)	1.54 (39.12)	1.72 (43.69)	1.96 (49.78)
F2	1.65 (41.91)	1.77 (44.96)	2.03 (51.56)	2.13 (54.10)	2.46 (62.48)



SERIES 70 10K PSI / 700 BAR / 7000 M
**SeaKing™ High-Pressure Subsea
 Connectors, Cables, and PBOF Assemblies**
 PBOF tubing: flexible elastomer

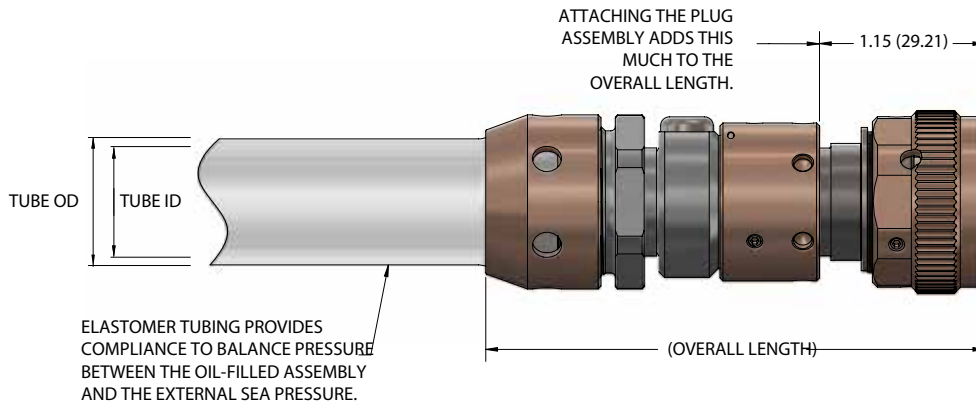
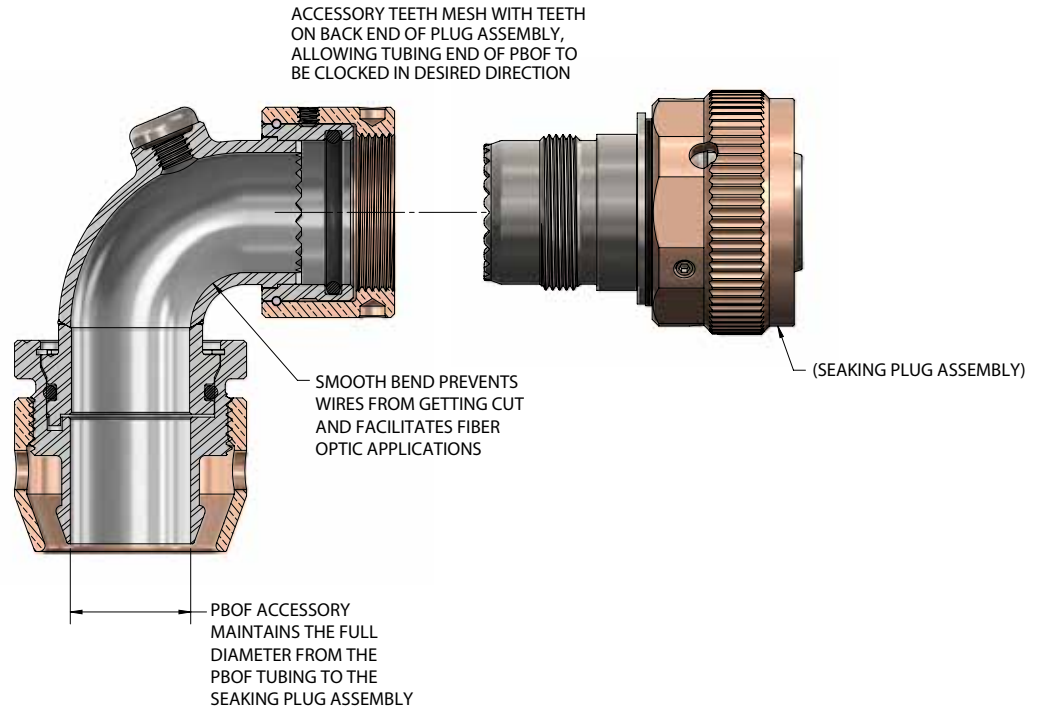

Dimensions					
Dim Callout	Shell Size				
	G	K	M	O	Q
TUBE ID	0.500	0.625	0.750	1.000	1.250
TUBE OD MIN	0.688	0.813	0.938	1.188	1.438
TUBE OD MAX	0.750	0.875	1.000	1.250	1.500

SUBSEA/DEEPWATER: SEAKING™





SERIES 70 10K PSI / 700 BAR / 7000 M
**SeaKing™ High-Pressure Subsea
 Connectors, Cables, and PBOF Assemblies**
 Cable assembly capabilities and accessories



TURNKEY OVERMOLDED AND REPAIRABLE CABLE ASSEMBLIES AND SPECIAL CONFIGURATIONS

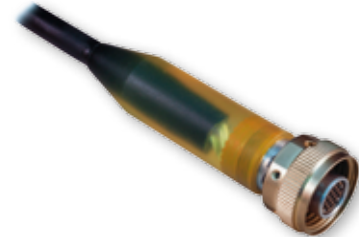

Amber overmold test sample demonstrates Glenair's harsh-environment, high-pressure cable overmolding and cable termination expertise (no voids, 360° material adhesion and cosmetic perfection)

 <p>10K psi overmolded CCP assembly</p>	 <p>10K psi overmolded 75 Ohm Coax hybrid assembly</p>	
 <p>Cabled bulkhead connector receptacle (BCR) assembly</p>	 <p>Special FCR assembly with additional mounting points and indexed flange</p>	 <p>Special Oil & Gas industry NE 606 overmolded cable</p>

PLUG PRESSURE CAP (MATES WITH 700-006/007)



Shell Size	Face Seal O-ring	Set Screw	Mating Torque
G	015	4-40 x 3/32	10 ft/lbs
K	017		12 ft/lbs
L	019		ft/lbs
M	020		12 ft/lbs
O	024		15 ft/lbs
Q	028		15 ft/lbs
R	029		ft/lbs

Basic Part Number	Plug Size	Body Material
709-002	-K	-Z1
	G, K, L, M, M O, P, Q, R See table	Z1 Stainless Steel TC Titanium Barrel and Coupling Nut

RECEPTACLE PRESSURE CAP (MATES WITH 700-001)

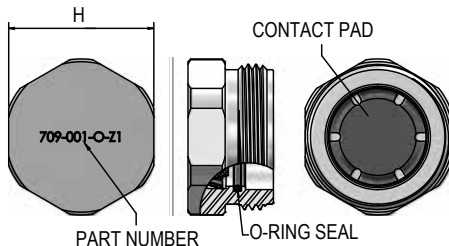

Plug Size	Hex H	Thread T (UN-2A)	O-Ring Size
G	.938 (23.83)	15/16-12	2-014
K	1.063 (27.00)	1 1/16-12	2-016
L	1.188 (30.18)	1 3/16-12	2-018
M	1.313 (33.35)	1 5/16-12	2-019
O	1.563 (39.70)	1 9/16-12	2-023
Q	1.813 (46.05)	1 13/16-12	2-028
R	1.938 (49.23)	1 15/16-12	2-029

Basic Part Number	Plug Size	Body Material
709-001	-O	-Z1
	G, K, L, M, M O, P, Q, R See table	Z1 Stainless Steel* TC Titanium

*For sizes G through O: Type 316
 for sizes Q and up: 2507 Super Duplex

SUBSEA/DEEPWATER: SEAKING™